

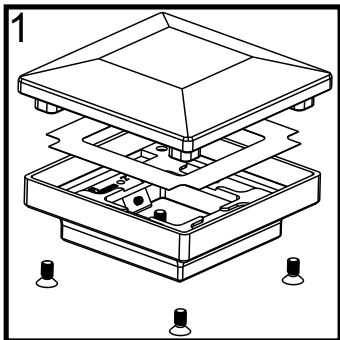

Installation Instructions 2" and 3" Flat Pyramid Caps Installed on Fe²⁶ or Al¹³ Posts

It is the responsibility of the installer to meet all code and safety requirements. The installer should determine and implement the appropriate installation techniques for each situation. The Fortress Company nor its distributors shall not be held liable for improper or unsafe installations.

Required Materials: Phillips Head Screw Driver, Eye Protection



1. The following components are included with the FortressAccents 2" and 3" Flat Pyramid Caps: Post Cap, Post Cap Base, Light Slot Cover, 4 - Machine Screws, 2 - Hex Head Set Screws, and a 2.5mm Hex Wrench.

Remove the 4 Machine Screws, located at each corner. Remove the Post Cap and Light Slot Cover. **Do not discard the screws.** They will be used again.

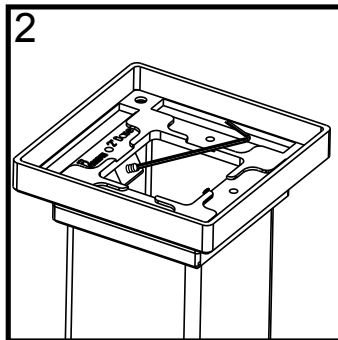

2. Place the Post Cap Base on the post. Using the supplied 2.5mm Allen Wrench tighten the two set screws. Adjust the screws to center and level the Post Cap on the post.

If installing the optional FortressAccents LED Cap Light Kit, reference those instructions before installing FortressAccents Flat Pyramid Cap.

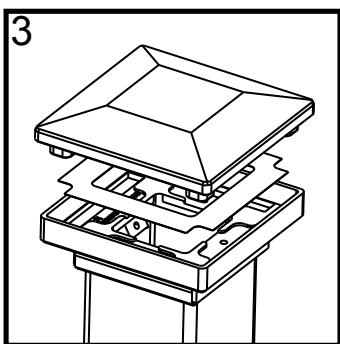

3. Place Light Slot Cover back onto Post Cap Base. Position Post Cap onto the Post Cap Base.

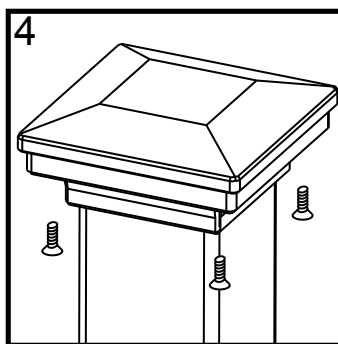

4. Secure Post Cap with the 4 Machine Screws that were removed in step 1.



Please contact ADI with any questions:

Ph: 1-800-335-5909

Web: www.absolutedist.com

Fax: 800-203-4495

Email: sales@absolutedist.com



Installation Instructions

3.5", 4", 5" and 6" Flat Pyramid Caps Installed on Wood or Composite Posts

It is the responsibility of the installer to meet all code and safety requirements. The installer should determine and implement the appropriate installation techniques for each situation. The Fortress Company nor its distributors shall not be held liable for improper or unsafe installations.

Required Materials: Phillips Head Screw Driver, Drill, 1/8" Drill Bit, Eye Protection

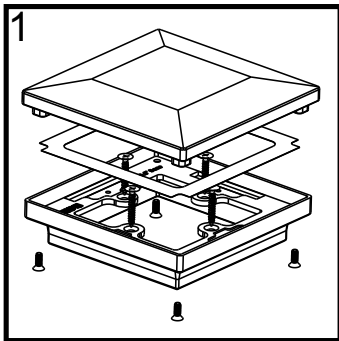

1. The following components are included with the FortressAccents 3.5", 4", 5", and 6" Flat Pyramid Caps: Post Cap, Post Cap Base, Light Slot Cover, 4 - Machine Screws, and 4 - #10 X 3/4" Wood Screws. Note: 5" and 6" Flat Pyramid Caps include a Composite Adapter with 4 - Pan Head Machine Screws.

Remove the 4 Machine Screws, located at each corner. Remove the Post Cap and Light Slot Cover. **Do not discard the screws.** They will be used again.

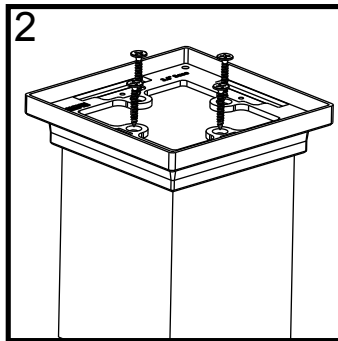

2. Place the Post Cap Base on the post and mark hole locations. Pre-drill holes with a 1/8" drill bit. Using the 4 supplied #10 X 3/4" Wood Screws, attach the Post Cap Base to post.

If the Flat Pyramid Cap is being installed on a vinyl post without a wood post insert, use a silicon adhesive to secure the Post Cap Base.

If installing the optional FortressAccents LED Cap Light Kit, reference those instructions before installing FortressAccents Flat Pyramid Cap.

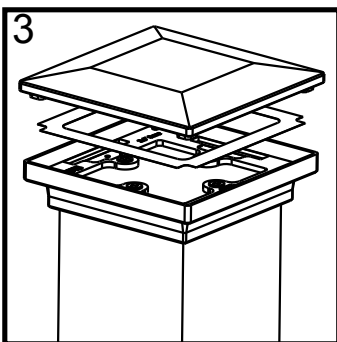

3. Place Light Slot Cover back onto Post Cap Base. Position Post Cap onto the Post Cap Base.

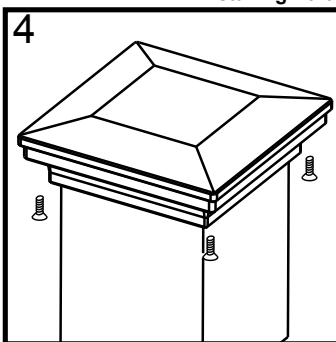

4. Secure Post Cap with the 4 Machine Screws that were removed in step 1.

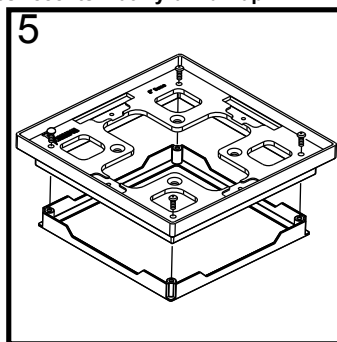

5. If installing FortressAccents 5" or 6" Flat Pyramid Caps, the adapter can be removed to allow cap to fit composite posts up to 5" and rough cut wood posts up to 6-1/8".



Installation Instructions

FortressAccents LED Cap Light Kit with FortressAccents Post Caps

It is the responsibility of the installer to meet all code and safety requirements. The installer should determine and implement the appropriate installation techniques for each situation. The Fortress Company or its distributors shall not be held liable for improper or unsafe installations.

WARNING – Risk of Electric Shock. Install all luminaires 10 feet (3.05 m) or more from a pool, spa, or fountain.

Required Materials: Phillips Head Screw Driver, Wire Cutters, Wire Strippers, Eye Protection

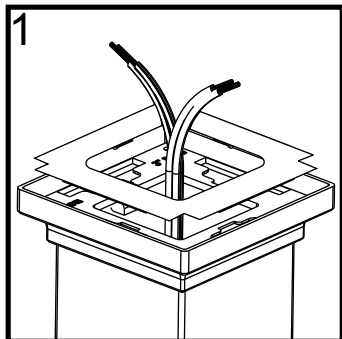

1. Run 18-2 gauge stranded outdoor wire (available from FortressAccents, please visit www.fortressaccents.com for dealer locations) by routing in close proximity to the luminaire or fitting, or next to a building structure such as a house or deck. Wire should not be buried. Install FortressAccents post cap base to post. FortressAccents post cap installation will vary depending on style of post. Remove light plugs from FortressAccents post cap base.

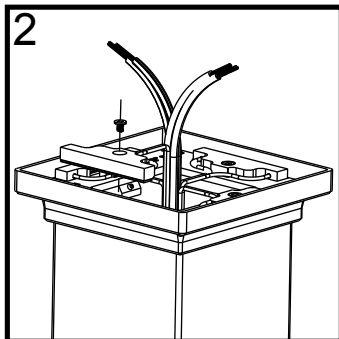

2. Place each LED module into an indentation in the FortressAccents post cap base with the LED's facing down. Secure the LED module with provided screws. You may eliminate the light emitted from any side of the FortressAccents post cap by clipping the wire of the unneeded LED module and wrapping the ends of wire with electrical tape.

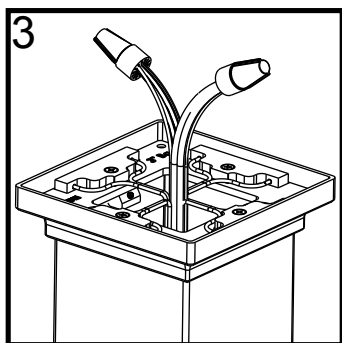

3. Strip the wire insulation back $\frac{1}{2}$ " from the field wiring. Connect wires with provided waterproof wire nuts. Wire connections can also be made below the deck surface. Note: Polarity must be maintained. Always connect the same side of 18-2 gauge wire with the same polarity (i.e. positive) marked on the LED Cap Light Kit.

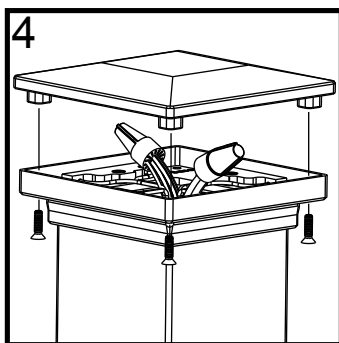

4. Before installing the post cap, make the connections on all of the LED cap modules you plan to use. Connect the field wiring to the transformer and turn on the lights to verify that the wiring is correct. Install the post cap cover with the provided fasteners.



Installation Instructions

FortressAccents LED Vertical Post Light

It is the responsibility of the installer to meet all code and safety requirements. The installer should determine and implement the appropriate installation techniques for each situation. The Fortress Company or its distributors shall not be held liable for improper or unsafe installations.

WARNING – Risk of Electric Shock. Install all luminaires 10 feet (3.05 m) or more from a pool, spa, or fountain.

Required Materials: Phillips Head Screw Driver, Wire Cutters, Wire Strippers, Drill, Drill Bits, T-25 Bit, Pencil, Eye Protection

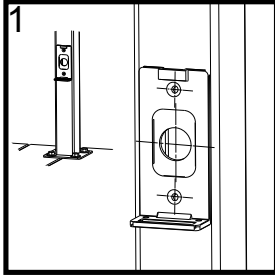

1. Run 18-2 gauge stranded outdoor wire (available from FortressAccents, please visit www.fortressaccents.com for dealer locations) by routing in close proximity to the luminaire or fitting, or next to a building structure such as a house or deck. Wire should not be buried. Place the LED Vertical Post Light Base on the post at the desired location (LED Vertical Post Light should be placed a minimum of 12" above ground level) with a pencil trace the hole pattern on the post. Mark the center point of the hole pattern and drill a 1" diameter hole in post.

For wood posts a channel will need to be routed into wood post to hide wires. Be sure to remove any metal shavings from the surface of deck, patio or balcony to prevent rust on the surface.

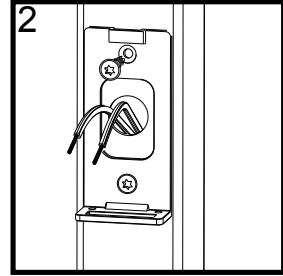

2. **Metal Post Installations** - Pre-drill screw holes using a 5/32" drill bit.

Wood Post Installations - Pre-drill screw holes using a 1/16" drill bit.

Attach LED Vertical Post Light Base to post with supplied screws. If 18-2 gauge wire is accessible pull approximately 6" of wire through 1" hole. The LED Vertical Post Light input wires can also be feed through the post to make the connections to the 18-2 gauge wire.

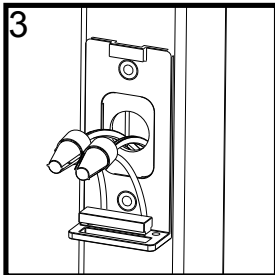

3. Strip the insulation back 1/2" from the 18-2 gauge wires and the LED Vertical Post Light feed wires. Using the supplied waterproof wire nuts connect wires. Wire connections can also be made below the deck surface. Note: Polarity must be maintained. Always connect the same side of 18-2 gauge wire with the same polarity (i.e. positive) marked on the LED Vertical Post Light wires. LED Vertical Post Light feed wires are 60" long.

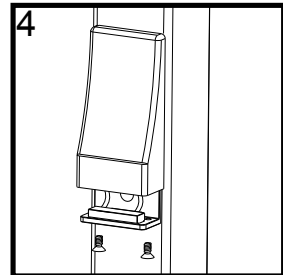

4. Carefully tuck wires out of the way. Place LED Vertical Post Light Cover over the installed LED Vertical Post Light Base and slide downward until cover is fully in place. Using the two supplied machine screws secure the cover to the base.



Installation Instructions FortressAccents LED Surface Mount Light

It is the responsibility of the installer to meet all code and safety requirements. The installer should determine and implement the appropriate installation techniques for each situation. The Fortress Company or its distributors shall not be held liable for improper or unsafe installations.

WARNING – Risk of Electric Shock. Install all luminaires 10 feet (3.05 m) or more from a pool, spa, or fountain.

Required Materials: 1" Forstner Bit, Drill, Wire Cutters, Wire Strippers, Rubber Mallet, Pencil, Eye Protection

Installation of LED Surface Mount Light on surfaces with excessive foot traffic is not recommended.

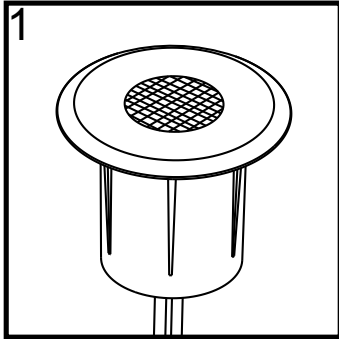

1. Run 18-2 gauge stranded outdoor wire (available from FortressAccents, please visit www.fortressaccents.com for dealer locations) by routing in close proximity to the luminaire or fitting, or next to a building structure such as a house or deck. Wire should not be buried. Place the LED Surface Mount Light in the desired location (LED Surface Mount Light should be placed a minimum of 12" above ground level) with a pencil mark the center point.

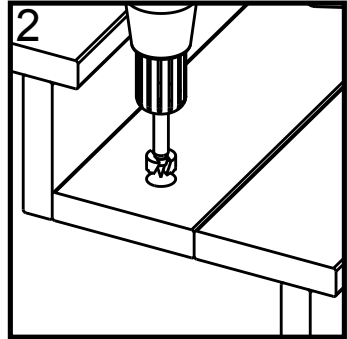

2. Drill a 1" hole (Fortress recommends using a 1" Forstner bit available from FortressAccents, please visit www.fortressaccents.com for dealer locations) at the desired location. Avoid locations that fall directly above stringers or other structural elements of the deck and wiring.

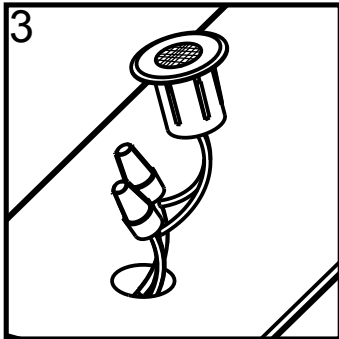

3. Strip the insulation back 1/2" from the 18-2 gauge wires and the LED Surface Mount Light LED feed wires. Using the supplied waterproof wire nuts connect the wires. Note: Polarity must be maintained. Always connect the same side of 18-2 gauge wire with the same polarity (i.e. positive) marked on the LED Surface Mount Light wires. LED Surface Mount Light feed wires are 60" long.

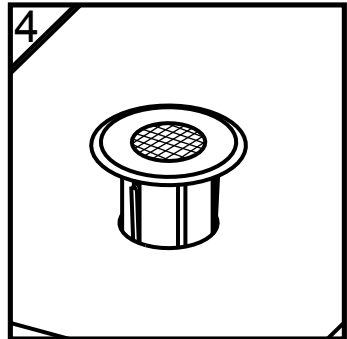

4. Feed wires through 1" hole. Insert LED Surface Mount Light into hole. Using a rubber mallet tap the light into the hole until the LED Surface Mount Light flange is flush with the deck surface.



Installation Instructions FortressAccents LED Universal Light

It is the responsibility of the installer to meet all code and safety requirements. The installer should determine and implement the appropriate installation techniques for each situation. The Fortress Company or its distributors shall not be held liable for improper or unsafe installations.

WARNING – Risk of Electric Shock. Install all luminaires 10 feet (3.05 m) or more from a pool, spa, or fountain.

Required Materials: Phillips Head Screw Driver, Wire Cutters, Wire Strippers, Drill, Drill Bits, Phillips Bit, T-25 Bit, Pencil, Eye Protection

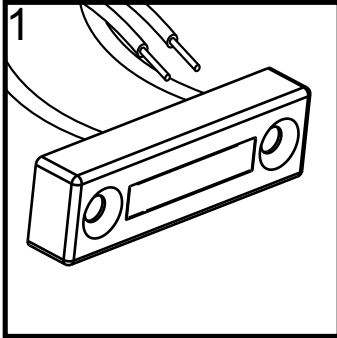

1. Run 18-2 gauge stranded outdoor wire (available from FortressAccents, please visit www.fortressaccents.com for dealer locations) by routing in close proximity to the luminaire or fitting, or next to a building structure such as a house or deck. Wire should not be buried. Place the LED Universal Light in the desired location (LED Universal Light should be placed a minimum of 12" above ground level) with a pencil mark the center points of screw holes. Screw holes are 1-3/4" on center.

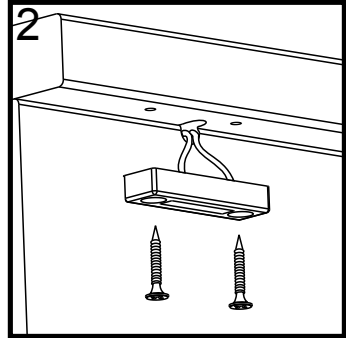

2. **Wood and Composite Installations** - When installing LED Universal Light on wood or composite surfaces pre-drill screw holes using a 1/16" drill bit. Using a 3/8" drill bit drill a hole to allow for wires to be routed through the surface. Hole must be placed so that the LED Universal Light housing does not pinch wires. Route wires through hole. Attach the LED Universal Light with supplied wood screws.

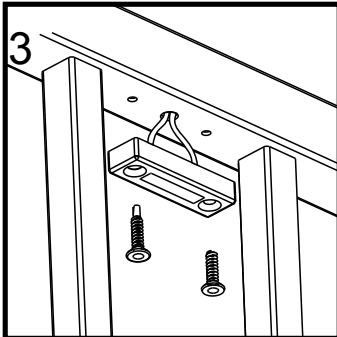

3. **Metal Installations** - When installing LED Universal Light on metal surfaces pre-drill screw holes using a 5/32" drill bit. Using a 3/8" drill bit drill a hole to allow for wires to be routed through the surface. Hole must be placed so that the LED Universal Light housing does not pinch wires. Route wires through hole. **For some installations, railing must be disassembled to route wires through railing.** Attach the LED Universal Light with supplied metal screws.

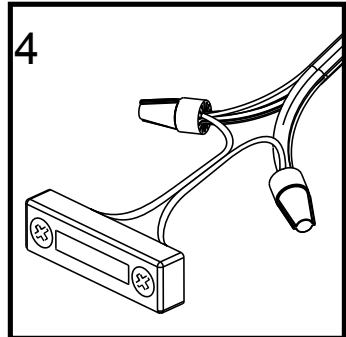

4. Strip the insulation back 1/2" from the 18-2 gauge wires and the LED Universal Light feed wires. Using the supplied waterproof wire nuts connect the wires. Note: Polarity must be maintained. Always connect the same side of 18-2 gauge wire with the same polarity (i.e. positive) marked on the LED Universal Light wires.



Installation Instructions FortressAccents 30W Transformer

It is the responsibility of the installer to meet all code and safety requirements. The installer should determine and implement the appropriate installation techniques for each situation. The Fortress Company or its distributors shall not be held liable for improper or unsafe installations.

WARNING – Risk of Electric Shock. Install power unit 10 feet (3.05 m) or more from a pool, spa, or fountain. Where the power unit is installed outdoors, connect power unit to a receptacle protected by a GFCI.

- **READ INSTALLATION INSTRUCTIONS BEFORE WIRING**
- **NOT FOR USE WITH DIMMERS**
- **FOR OUTDOOR USE ONLY. MOUNT AT LEAST 12" (30.48 cm) ABOVE GROUND**
- **NOT FOR USE WITH SUBMERSIBLE FIXTURES**
- **DO NOT CONNECT TWO OR MORE TRANSFORMERS IN PARALLEL**

Required Materials: Phillips Head Screw Driver, Wire Cutters, Wire Strippers, Eye Protection, Tape Measure, Power Switch (not included)

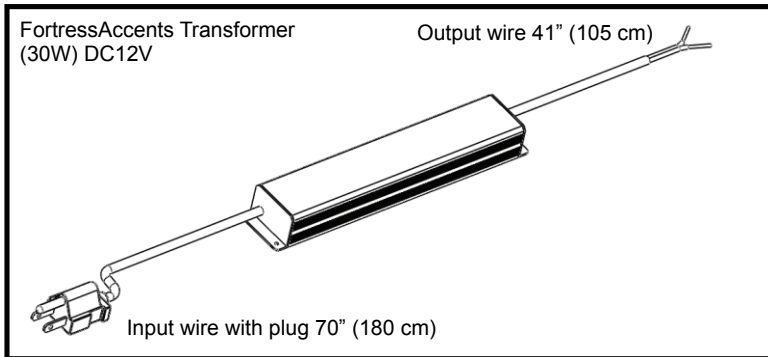

Transformer must be installed more than 12" (30.48 cm) above the ground.

Determine the best location for the transformer based on your lighting layout. Transformer should be located as close to the first luminaire as possible. Supplied input wire with plug must be connected to a GFCI protected outlet with a hooded flush type cover plate receptacle marked "Wet Location". **Do not to use an extension cord.**

If no GFCI protected outlet with a hooded flush type cover plate receptacle marked "Wet Location" is available, a licensed electrical contractor must install a GFCI outlet at the required location.

Run 18-2 gauge stranded outdoor wire by routing in close proximity to the luminaire or fitting, or next to a building structure such as a house or deck. Wire should not be buried.

Total Wattage of lights in system should not exceed 30 watts. If additional lights are required a second transformer must be used. **Do not connect two or more transformers in parallel.**



Installation Instructions

FortressAccents Premium Transformer (40W)

It is the responsibility of the installer to meet all code and safety requirements. The installer should determine and implement the appropriate installation techniques for each situation. The Fortress Company or its distributors shall not be held liable for improper or unsafe installations.

WARNING – RISK OF ELECTRIC SHOCK. Install power unit 10 feet (3.05 m) or more from a pool, spa, or fountain. Where the power unit is installed outdoors, connect power unit to a receptacle protected by a GFCI.

- **READ INSTALLATION INSTRUCTIONS BEFORE WIRING**
- **NOT FOR USE WITH EXTERNAL DIMMERS**
- **FOR OUTDOOR USE ONLY. MOUNT AT LEAST 12" (30.48 cm) ABOVE GROUND**
- **NOT FOR USE WITH SUBMERSIBLE FIXTURES**
- **DO NOT CONNECT TWO OR MORE TRANSFORMERS IN PARALLEL**

Required Materials: Phillips Head Screw Driver, Wire Cutters, Wire Strippers, Eye Protection, Tape Measure

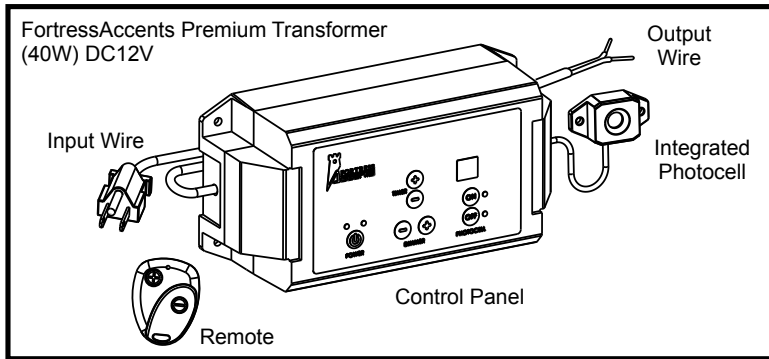

Transformer must be installed more than 12" (30.48 cm) above the ground.

Determine the best location for the transformer based on your lighting layout. Transformer should be located as close to the first luminaire as possible. Supplied input wire with plug must be connected to a GFCI protected outlet with a hooded flush type cover plate receptacle marked "Wet Location". **Do not to use an extension cord.**

If no GFCI protected outlet with a hooded flush type cover plate receptacle marked "Wet Location" is available, a licensed electrical contractor must install a GFCI outlet at the required location.

Mount Photocell to wall or other solid surface with supplied screws. Photocell should be mounted in a shade free location. Be sure not to mount photocell in a location that is influenced by nighttime lighting. Placement of photocell can be adjusted until the system comes on at the desired light level.

Run 18-2 gauge stranded outdoor wire by routing in close proximity to the luminaire or fitting, or next to a building structure such as a house or deck. Wire should not be buried.

Total wattage of lights in system should not exceed 40 watts. If additional lights are required a second transformer must be used. **Do not connect two or more transformers in parallel.**

Control Panel

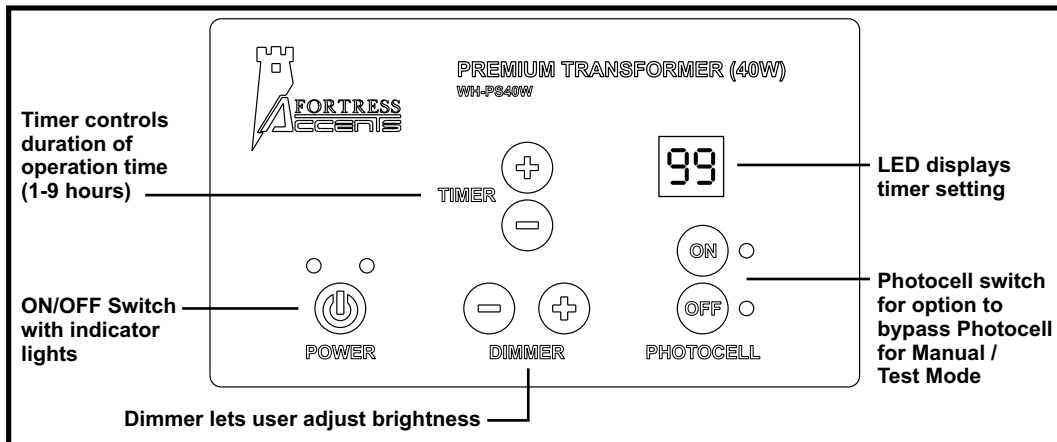

ON/OFF (Manual / Test Mode)

When power is "ON" green indicator light is illuminated

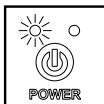

When power is "OFF" red indicator light is illuminated

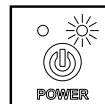

Timer and LED Display

In Manual / Test Mode with power "ON", default Timer setting will be displayed as 99.

In Photocell Mode, Timer can be set in 1 hour increments from 1 to 9 hours. Adjust timer by pressing the +/- buttons.



Photocell

Photocell ON/OFF allows user to bypass the Photocell to operate the Transformer in Manual / Test Mode. Photocell is "OFF" when red indicator light is illuminated. Photocell is "ON" when green indicator light is illuminated. **Photocell has a 2 minute delay.**

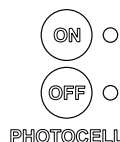

Dimmer

Dimmer provides user with control over brightness of all LED lights powered by the Premium Transformer (40W). Brightness can be incrementally changed by short pushes of the +/- buttons or hold +/- buttons for sliding adjustment. **FortressAccents LED Surface Mount Lights dim at different levels compared to other FortressAccents lighting components.**

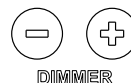

Remote (10 yard range)

Remote provides user with control over brightness of all LED lights powered by the Premium Transformer (40W). Brightness can be incrementally changed by short pushes of the +/- buttons or hold +/- buttons for sliding adjustment. **FortressAccents LED Surface Mount Lights dim at different levels compared to other FortressAccents lighting components.**

