



Installation Guide For:



**This Packet MUST Accompany
Materials To Job Site**

Call 1-800-335-5909 for Installation Support

Drawing Enclosed



TABLE OF CONTENTS

AS&D Railing Overview 2 - 3

Railing Component Guide 6 - 8

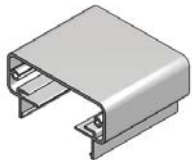

Series 200 Top Rail 10 - 12

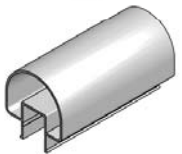

Series 100 Top Rail 14 - 15

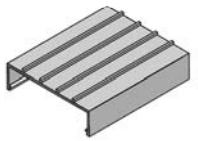

Series 400 Top Rail 18 - 19

Surface Mount Post 22 - 23

Fascia Post w/ Bracket 26 - 29

Fascia Post w/o Bracket 32 - 35

Surface Mount Conversion 38 - 41

Gate Installation 44 - 46

Cable Railing Install 48 - 49

Framework for AS&D™ Aluminum Rail and Cable System

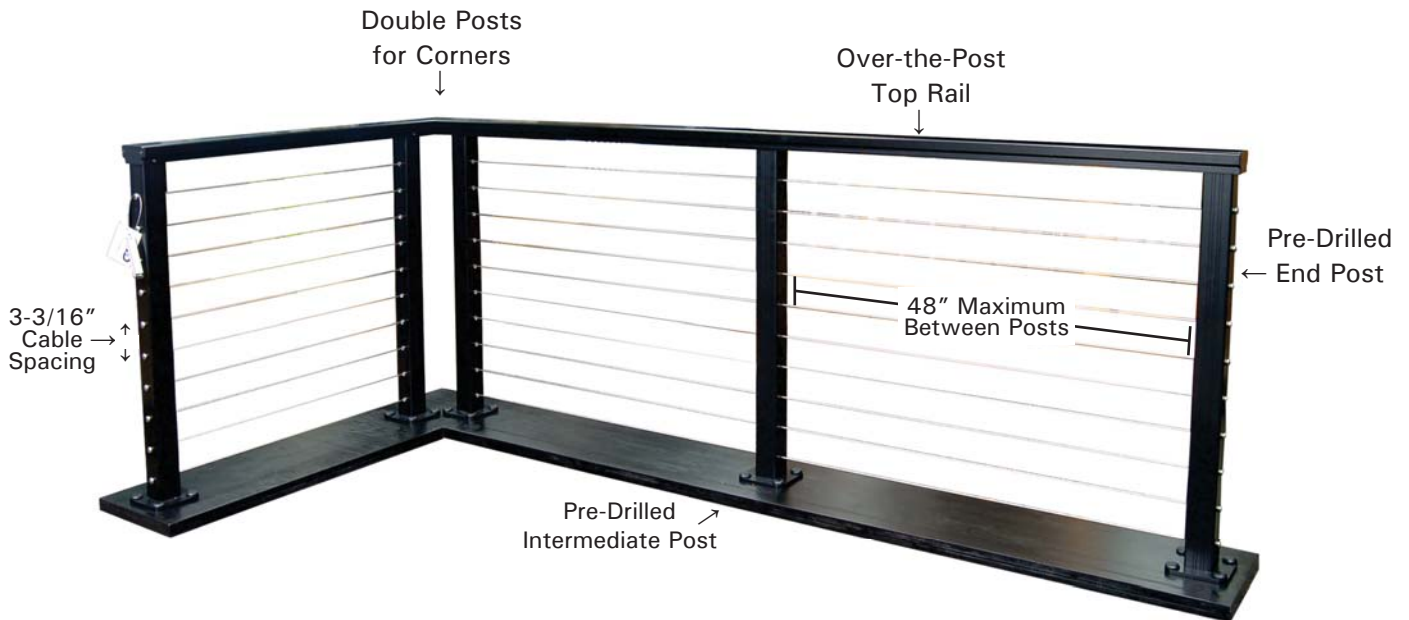

Rail Overview

Manufactured in the USA using environmentally-sound aluminum, AS&D™ Aluminum Rail and Cable System has been designed, engineered and tested specifically for a cable application rail system. The aluminum framework and stainless steel cable allows for railings to be lightweight, while still retaining exceptional durability. Railings will not rust, rot, swell, warp, twist, split, or crack and require little to no user maintenance.

Rail Guidelines

To keep the cable from deflecting beyond 4", to meet code requirements, AS&D™ rail requires that the cable be supported with a post every 50" on center or less. Cables are to be spaced at 3-3/16" spacing on center. Two posts must be used to create a 90 degree corner and/or a 45 degree turn. Cable can start and stop at the corner or it can pass through the corner. Top rail is required for all railing installations.

Posts

AS&D™ posts for level and stair railings are pre-drilled and ready for cable installation. Posts for stairs come with base plate unattached to maximize installation flexibility, which allows the post to accommodate most stair applications. All posts are available for surface mount or fascia mount and available for 36" and/or 42" rail heights.

Top Rails

There are 3 styles of top rail that AS&D™ railing utilizes:

Series 200 is a contemporary flat top rail most often used for level applications. Can be used for stairs with the addition of a secondary handrail system.

Series 100 has a rounded profile that qualifies as a graspable rail and is most commonly used for stairs.

Series 400 is a flat top rail that is designed to accept a wood or composite cap rail.

Available Colors:

Colors shown are approximate representation



Anodized (Silver)



Black



Bronze



White

Top Rail Profiles

Series 200

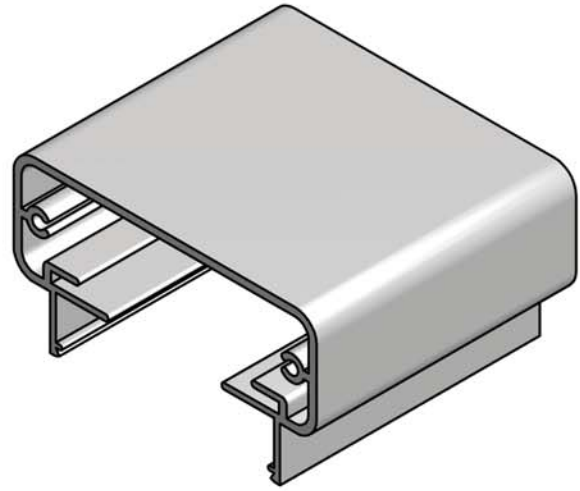
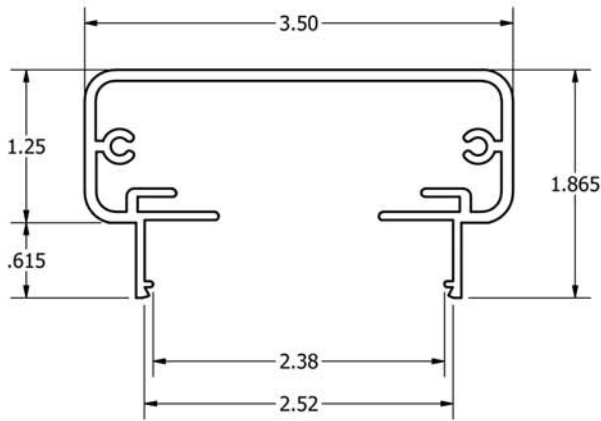

Series 100

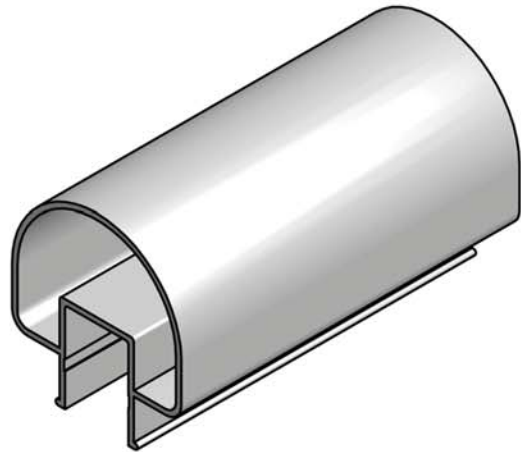
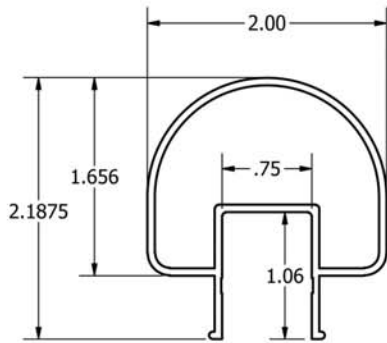

Series 400

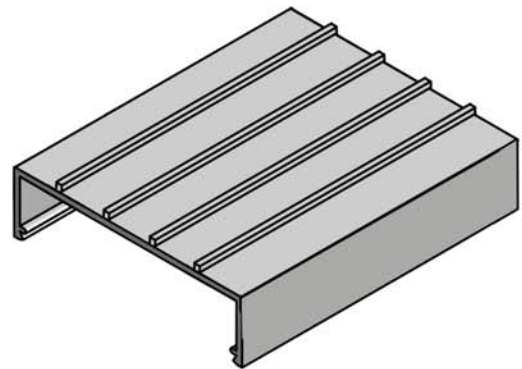
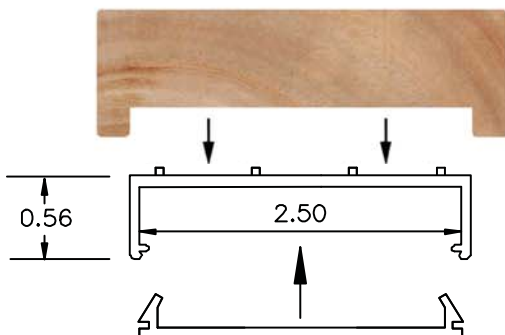



AS&D

Aluminum Railing & Cable Systems

Components Guide



Posts / Base Plates / Brackets



Surface Mount End Post
 2-3/8" X 35" Post - 10 Holes
 2-3/8" X 41" Post - 12 Holes
 (29/64" Pre-Drilled Holes)

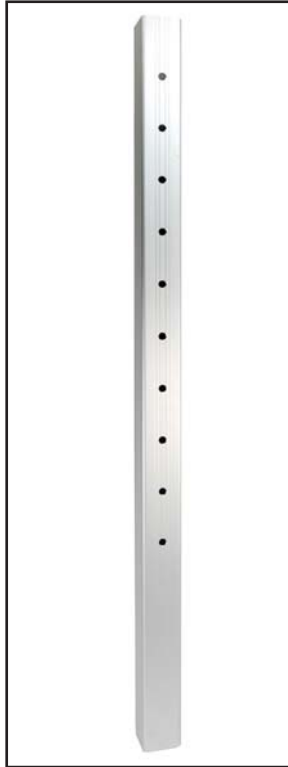

Fascia Mount End Post
 2-3/8" X 46" Post - 10 Holes
 2-3/8" X 52" Post - 12 Holes
 (29/64" Pre-Drilled Holes)

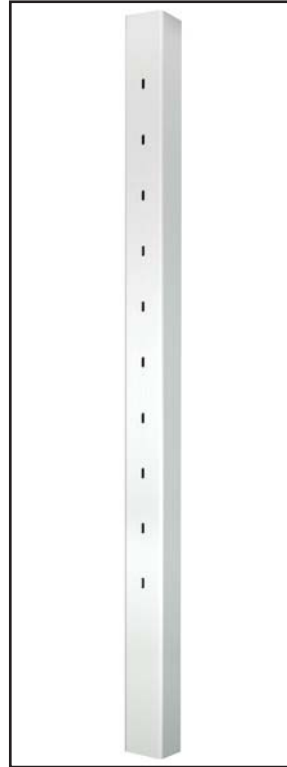

Fascia Mount Stair Post
 2-3/8" X 46" Post - 10 Holes
 2-3/8" X 52" Post - 12 Holes
 (Pre-Drilled Slotted Holes)



Standard Base Plate
 (5" X 5")
 (Converts fascia post to surface mount)



Knee Wall Base Plate
 (5" X 5")
 (Allows post to be mounted on angled knee wall)



Surface Mount Intermediate Post
 2-3/8" X 35" Post - 10 Holes
 2-3/8" X 41" Post - 12 Holes
 (3/16" Pre-Drilled Holes)



Fascia Mount Intermediate Post
 2-3/8" X 35" Post - 10 Holes
 2-3/8" X 41" Post - 12 Holes
 (3/16" Pre-Drilled Holes)



Undrilled Post
 2-3/8" X 46" Post - Blank
 2-3/8" X 52" Post - Blank
 (No Holes)



Line Fascia Bracket



Outside Corner Fascia Bracket

Top Rails / End Plates / Splices

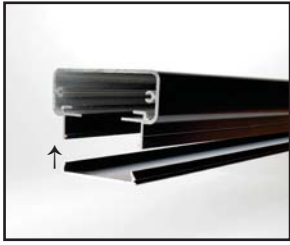

Series 200 Top Rail
w/ Flat Infill
Item #: ASTR200XXX4KIT
Item #: ASTR200XXX8KIT

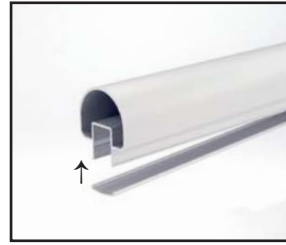

Series 100 Top Rail
w/ Flat Infill
Item #: ASTR100XXX4KIT
Item #: ASTR100XXX8KIT



Series 200 Top Rail
End Plate w/ Screws
Item #: ASEP200XXX



Series 100 Top Rail
End Plate w/ Screws
Item #: ASEP100XXX



Series 200 Top Rail
Straight Splice
Item #: ASSPL200



Series 100 Top Rail
Intermediate Post Fitting
(IPF)
Item #: ASIPFSETXXX



Series 200 Top Rail
90 Degree Splice
Item #: ASSPL20090



Series 100 Top Rail
1" Rail Connecting
Block (RCB). Connects
Rail to Face of Post
Item #: RCB1



Series 200 Top Rail
135 Degree Splice
Item #: ASSPL200135



Series 100 Top Rail
12" Rail Connecting
Block (RCB12). Used as
Splice for Top Rail
Item #: RCB12



Series 200 Top Rail
Stair Splice
Item #: ASSPLST



Series 400 Top Rail
w/ Flat Infill
Item #: ASTR400XXX4KIT
Item #: ASTR400XXX8KIT

Hardware / Accessories



**Bolt Cap and Cup Washer
for 3/8" Diameter Fasteners**
Item #: ASBOLTCAPXXXKIT

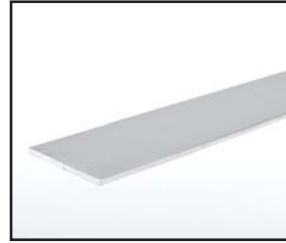

**Internal Post Brace (IPB)
32" or 40" Internal Support
for Cable End Post**
Item #: ASEPIF36
Item #: ASEPIF42



**3-1/2" x 3/8" Stainless
Steel Lag Screw**
Item #: ASSCREWLAG5



**Bee's Wax and T30 Drill Bit
(For Installing Base Plate)**
Item #: ASDINSTKIT



#14 - 1" Fascia Bracket Screw
Item #: ASSSFS



**Push-Lock
Release Key**
Item #: PLKEY



#10 - 3/4" Screw
Item #: ASSCREWXXXW805



Cable Cutter
Item #: C7HIT



Post Cap for 2-3/8" Post
Item #: ASPCXXX



Cable Gripping Pliers
Item #: PLIERS



**Touch up Paint
(Spray Can or Paint Pen)**
Item #: ASPAINTXXX



Cable Cleaner & Protectant
Item #: EZCLEAN

AS&D

Aluminum Railing & Cable Systems

Series 200 Top Rail



Series 200 Top Rail for Level Applications



Attaching to End Post

Rail slides over top of post and attaches with 2 ea. screws. 1 screw on each side. Top rail end plate can be attached before or after installation.

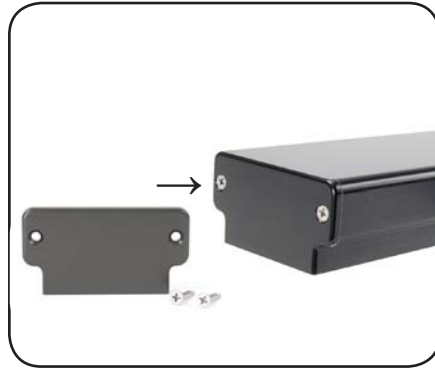

Attaching End Plate

End plate goes on open end of top rail where rail ends. Use 2 ea. included machine screws to attach to top rail.



Attaching to Intermediate Post

Rail slides over top of post and attaches with 2 ea. screws. 1 screw on each side.

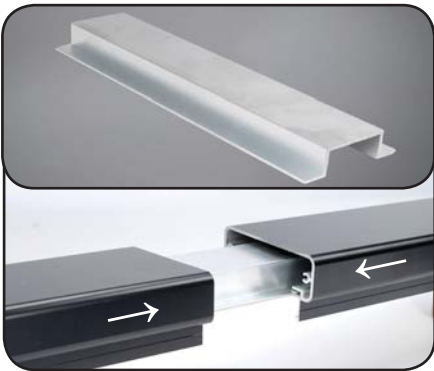

Series 200 Level Splice - 1

Level splice slides into each end of the rail. Splice must be secured into place with 8 ea. screws from the underside of the top rail.



Series 200 Level Splice - 2

Use 8 ea. screws to secure splice into rail from the underside.



Option to Splice Over a Post

Splice must be installed into rail and then rail mounts to post.



Splice Between Posts

Use splice to connect rails together where the rails meet between posts.

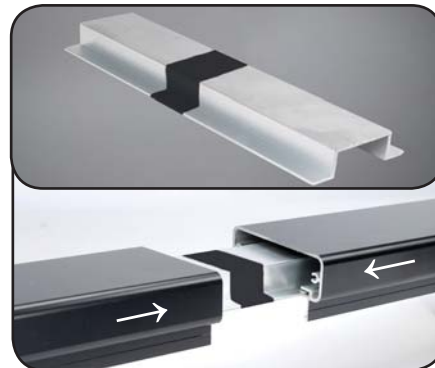

Painting Splices (Optional)

Paint a section of the splice where the connection is being made. Applies to all colors.



Painting Top Rail Ends (Optional)

Paint the rail ends on all splices or an inconspicuous splice. Applies to all colors.

Series 200 Top Rail for Level Applications

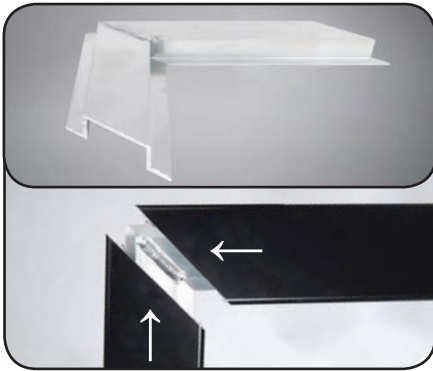

Series 200 - 90 Degree Splice
Splice slides into each end of the rail.
Splice must be secured into place
with 8 ea. screws from underside.
(Top rail must be mitered).



90 Degree Splice - Application
Finished look using 90 degree
splice to connect rails.

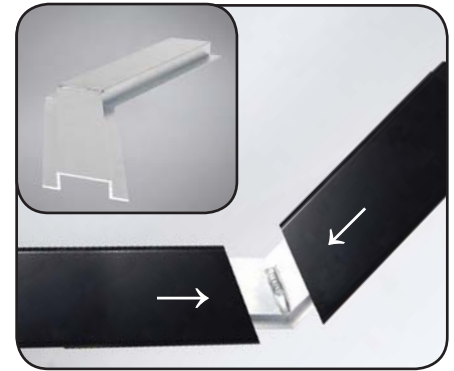

Series 200 - 135 Degree Splice
Splice slides into each end of the rail.
Splice must be secured into place
with 8 ea. screws from underside.
(Top rail must be mitered).



135 Degree Splice - Application
Finished look using 135 degree
splice to connect rails.



Series 200 - Flat Infill
Cut flat infill to length and snap
into bottom side of top rail. **Install
prior to tensioning the cables.**

Series 200 Top Rail Terminating Into Post or Column

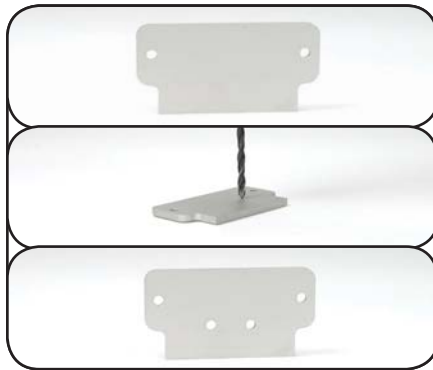

Series 200 Terminating into Post - 1
Convert end plate into a bracket by
drilling holes through the end plate for
screws.



Series 200 Terminating into Post - 2
Use 2 ea. included screws to
attach end plate to top rail.
Then use holes that were created to
connect top rail into post or column.



Series 200 Terminating into Post - 3
Finished look of attached top rail to
existing post or column.

Series 200 Top Rail for Stair Applications



Series 200 - Stair Splice
Splice slides into each end of the rail. Bend splice to the correct angle of the stairs and secure splice into place with 8 ea. screws.



Stair Splice - Application 1
Example of rail mitered down the stairs in a continuous line.



Stair Splice - Application 2
Example of rail mitered down the stairs in with a 90 degree turn.

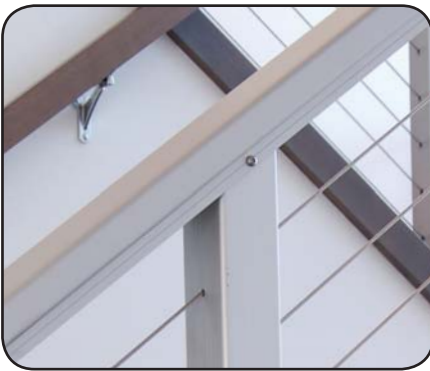

Series 200 Stair Intermediate Post
Post must be cut at the angle of the stairs. Rail slides over top of post and attaches with 2 ea. screws.
1 screw on each side.



Series 200 Stair End Post
Post must be cut at the angle of the stairs. Rail slides over top of post and attaches with 2 ea. screws.
1 screw on each side.

Please Note
Series 200 Top Rail does not qualify as a graspable rail down the stairway. A secondary handrail must be used or Series 100 top rail can be used.



Series 200 Top Rail with Surface Mount Post - Anodized

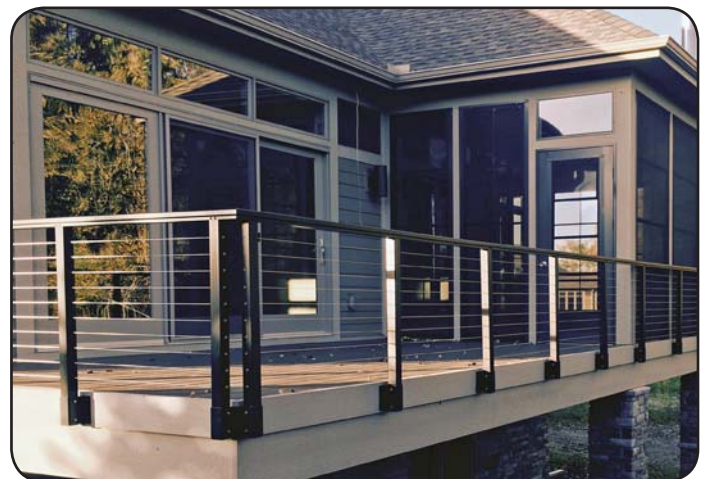

Series 200 Top Rail with Fascia Mount Post - Black

AS&D

Aluminum Railing & Cable Systems

Series 100 Top Rail



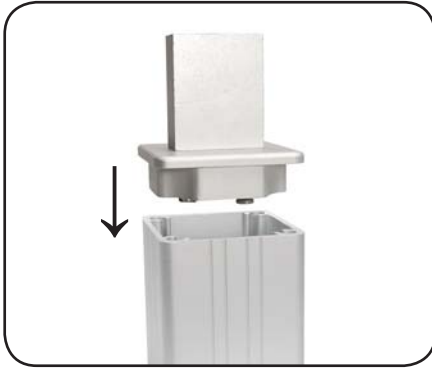

Intermediate Post Fitting (IPF)

IPF fitting slides down into post. Secure fitting in place with 2 ea. screws included. 1 screw on each side.



Attaching Top Rail to Post

Rail slides over IPF fitting and attaches with 2 ea. screws. 1 screw on each side.



Series 100 - Intermediate Post

Once top rail is installed on post, snap in the bottom infill for a finished look.



Series 100 - End Post

Rail slides over IPF fitting and attaches with 2 ea. screws. 1 screw on each side. Top rail end plate can be attached before or after installation.

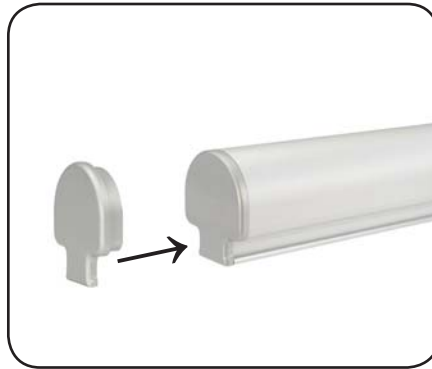

Series 100 End Plate

Use adhesive to secure end plate to top rail.

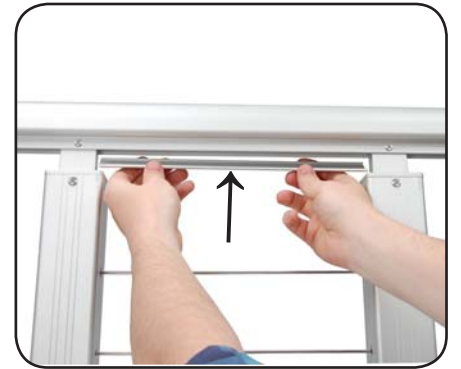

Series 100 - Flat Infill

Cut flat infill to length and snap into bottom side of top rail. **Install prior to tensioning the cables.**



Series 100 Rail Connecting Block (RCB)

Use RCB12 to splice rails together. RCB12 slides into both top rails and then secures with 8 ea. screws.



Series 100 Splice between Posts

RCB12 slides into each end of the rail. RCB12 must be secured into place with 8 ea. screws. Allows rails to be spliced between posts.



Connecting on IPF Fitting

Top rails may also be spliced on top of a post using the IPF fitting. This does not require the use of a splice.



Top Rail Terminating into Post - 1

Use 12" Rail Connecting Block (RCB12) to cut an angled piece out of. Then screw the cut piece to the post with 2 ea. screws.



Top Rail Terminating into Post - 2

Top rail mounts into the side of the post using the rail connecting block. Attach rail with 2 ea. screws. 1 screw on each side.

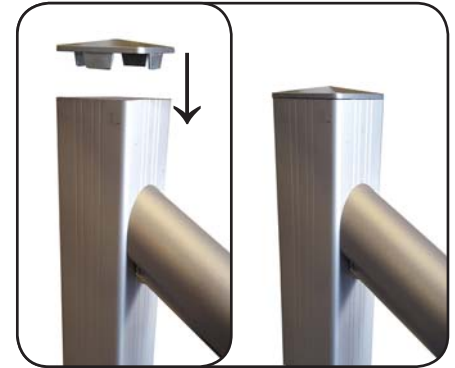

Post Cap Installation

If terminating series 100 top rail into the post, a post cap must be installed to finish the rail. Use adhesive to secure post cap into post.



**Series 100 Top Rail
Over the post using IPF Fitting**



**Series 200 Top Rail - Level
Series 100 Rail - Stair**



**Series 200 Top Rail - Level
Series 100 Rail - Stair**



Series 100 Rail - Terminating Into End Posts



AS&D

Aluminum Railing & Cable Systems

Series 400 Top Rail



Series 400 Top Rail for Level Applications

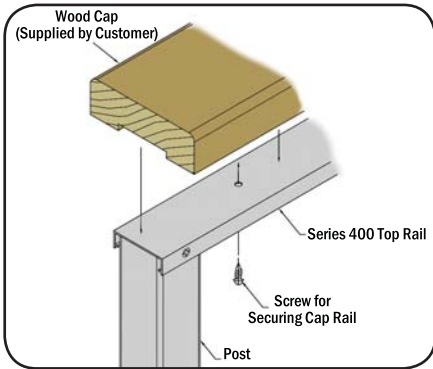

Series 400 Top Rail

Allows for a wood / composite cap rail to be attached to the AS&D rail system. Cap rail can be screwed directly to top rail or dadoed out.



Attaching to End Post

Rail slides over top of post and attaches with 2 ea. screws. 1 screw on each side.



Attaching to End Post

Wood / Composite cap rail attaches to series 400 top rail by screws from the bottom side.



Attaching to Intermediate Post

Rail slides over top of post and attaches with 2 ea. screws. 1 screw on each side.



Attaching to Intermediate Post

Wood / Composite cap rail attaches to series 400 top rail by screws from the bottom side.



Screwing from bottom Side

Wood / Composite cap rail attaches to series 400 top rail by screws from the bottom side. Do this before installing flat infill.



Straight Splice Option 1

Both top rails slide over top of post and attaches with screws. 1 screw on each side. (Total of 4 ea. screws).

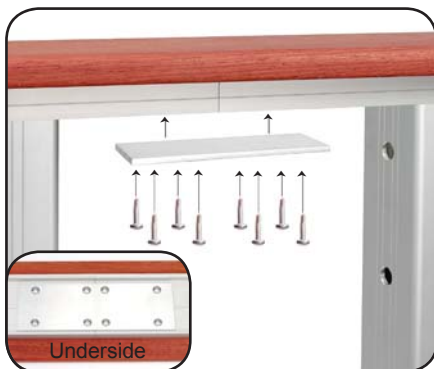

Straight Splice Option 2

Splice must be secured into place with 8 ea. screws from underside. Splice is made from a cut piece of IPB (flat aluminum stock).



Straight Splice Option 3

Use Wood / Composite as splice to connect rails together where the Series 400 rails meet between posts.

Series 400 Top Rail for Level Applications



45° Splice

Splice must be secured into place with 6 ea. screws from underside. (Top rail must be mitered).
Splice is made by cutting 2-3/4" piece from IPB (flat aluminum stock).



90° Splice

Splice must be secured into place with 6 ea. screws from underside. (Top rail must be mitered).
Splice is made by cutting 2-3/4" piece from IPB (flat aluminum stock).



Series 400 - Flat Infill

Cut flat infill to length and snap into bottom side of top rail. **Install prior to tensioning the cables.**

Special Notes:

- Series 400 top rail is **NOT** structural on its own. Series 400 top rail is designed to allow for the attachment of a wood or composite cap rail with the intent that the wood or composite rail will add structural integrity.
- Cap rail **MUST add 1"** or more to overall rail height to reach the required rail heights for both 36" and 42" rails.
- A scarf joint should be used to allow for expansion and contraction of cap rail.
- Butt joints of the cap rail and top rail should be staggered.



Series 400 Top Rail with Composite Cap Rail



Series 400 Top Rail with Wood Cap Rail



AS&D

Aluminum Railing & Cable Systems

Surface Mount Posts



Installation Guide

Surface Mount Post Installation

For 36" AS&D™ Aluminum Railing and Cable System

Materials needed for Installation:



Surface Mount Post



3/8" Lags or Carriage Bolts

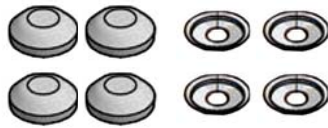

Bolt Caps & Cup Washers

Overview

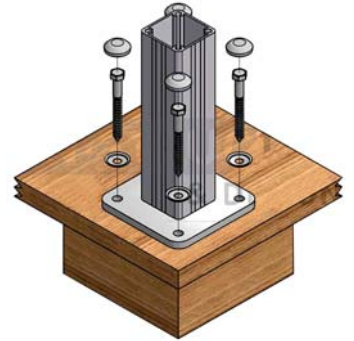

It is the responsibility of the installer to meet all code and safety requirements, and to obtain all required building permits. The deck and railing installer should determine and implement appropriate techniques for each installation situation. AS&D™ or its distributors shall not be held liable for improper or unsafe installations. Determine appropriate layout and post spacing - **Maximum post spacing of 50" on center.** Ensure that proper blocking is in place before mounting post.

Post Mounting Options

Surface Mount using Carriage Bolt

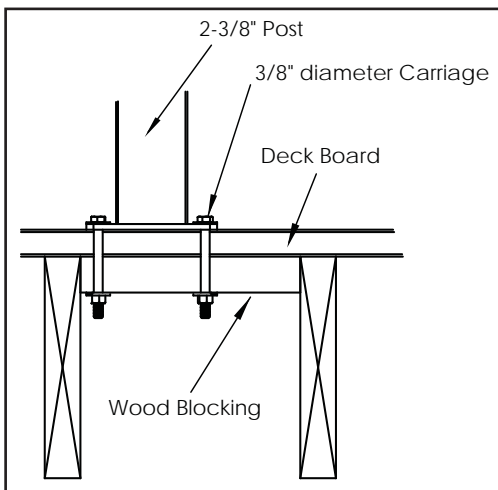

Surface Mount using Lag Bolt

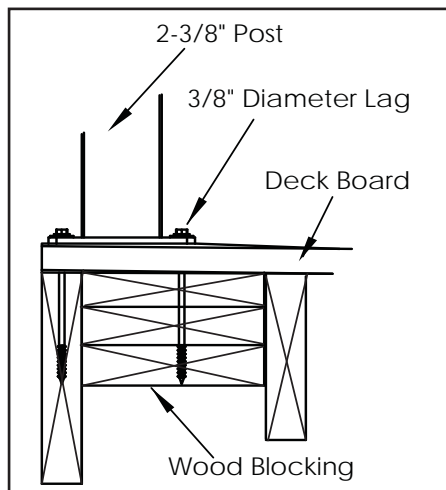

Surface Mount using Concrete Anchor

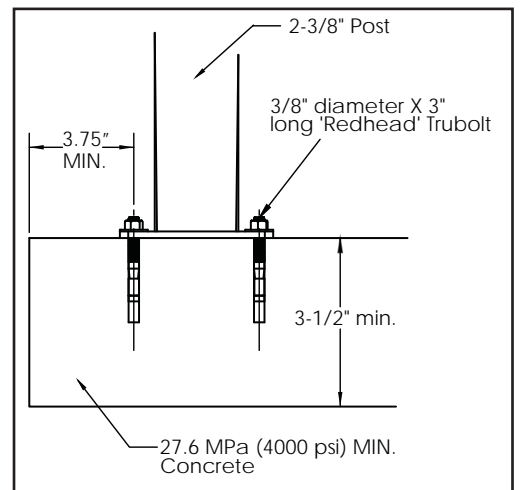

- Wood blocking must be constructed with treated dimensional lumber
- Secure wood blocking to deck frame on all for sides - using #10 x 3-1/2" deck screws
 - Wood blocking must be constructed with a minimum thickness of 1-1/2"
- Base plate holes **MUST** be positioned a minimum 1/2" from the edge of deck board
 - Use only 3/8" diameter lag screws or carriage bolts to attach post
 - Secure each post with four bolts

Surface Mount Post Installation

For 36" AS&D™ Aluminum Railing and Cable System



Step 1:
Determine location of post and mark hole locations.



Step 2:
Remove post and pre-drill pilot holes to accept 3/8" diameter lag or carriage bolt.



Step 3:
Install cup washer under head of each fastener and drive fastener into blocking.



Step 4:
Ensure post is plumb, adjust as needed. Tighten fasteners and ensure proper engagement into blocking.



Step 5:
Press bolt caps onto cup washer to finish post

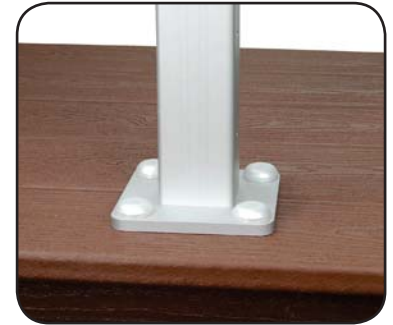

Step 6:
Finished Installation.

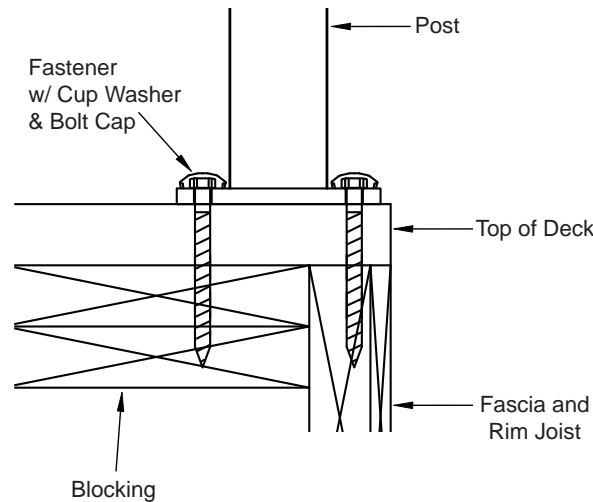



AS&D

Aluminum Railing & Cable Systems

Fascia Mount w/ Brackets





Installation Guide Fascia Mount: **End Post** with Bracket

For 36" AS&D™ Aluminum Railing and Cable System

Materials needed for Installation:



3/8" Lags or Carriage Bolts



Bolt Caps & Cup Washers



Fascia Bracket Screws



Fascia Bracket



Bottom Cap



46" End Fascia Post

Overview

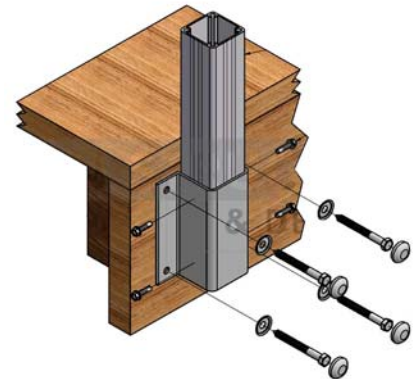

It is the responsibility of the installer to meet all code and safety requirements, and to obtain all required building permits. The deck and railing installer should determine and implement appropriate techniques for each installation situation. AS&D™ or its distributors shall not be held liable for improper or unsafe installations.

Determine appropriate layout and post spacing - **Maximum post spacing of 50" on center.**

Ensure that proper blocking is in place before mounting post.



Step 1:

Determine location of end post fascia bracket. Ensure bracket is plumb, mark holes, remove bracket and drill pilot holes to accept 3/8" diameter lag or carriage bolt.



Step 2:

Install cup washer under head of each fastener and drive fastener loosely into blocking.



Step 3:

Ensure bracket is plumb, adjust as needed. Tighten fasteners and ensure proper engagement into blocking.



Step 4:

Install fascia end bracket at opposite end. Measure down from deck boards the same distance as the first bracket.



Step 5:

Set post into bracket and ensure top of post is at 35-1/2" above deck surface to meet 36" rail height requirements.



Step 6:

While holding post in place, mark bottom of post at bracket edge. Cut post end using a sharp carbide 80 tooth blade on a miter box.

Fascia Mount: End Post with Bracket

For 36" AS&D™ Aluminum Railing and Cable System



Step 7:

Place bottom cap in post. Secure in place with 2 ea. countersunk screws or epoxy adhesive.



Step 8:

With bottom cap installed and post laying horizontally, slide 2 ea. Internal Post Braces (IPB) into existing channels parallel to pre-drilled cable fitting holes as shown.



Step 9:

Maintain contact with bottom of post on deck surface. Slowly pivot post vertically until plates slide to bottom of post, resting on cap.



Step 10:

On each side of fascia bracket mark two holes at center line at the same level as the bracket fasteners. Pilot with a 1/4" drill bit.



Step 11:

With bottom of post flush with bottom of bracket, secure post into bracket by installing 4 ea. self-drilling #14 x 1" screws.



Step 12:

Install nylon bolt cap covers for a finished look.



Finished fascia mount bracket with post installed.

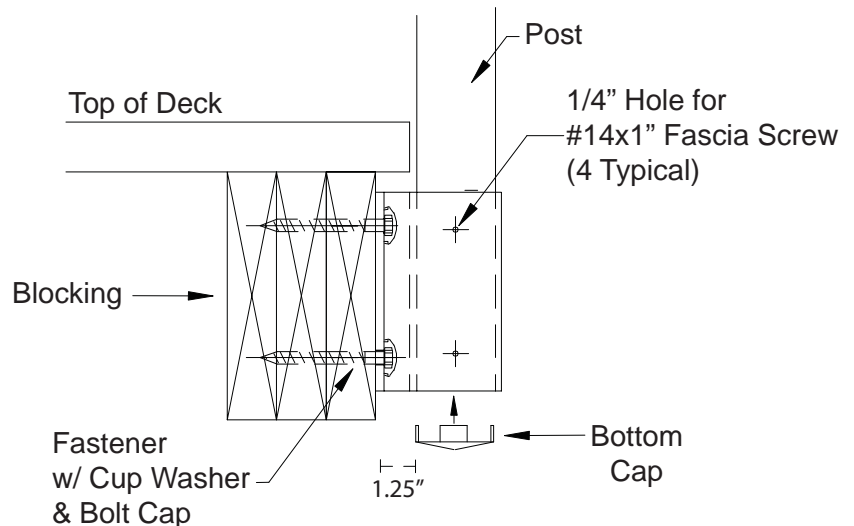



Installation Guide Fascia Mount: **Intermediate Post** with Bracket

For 36" AS&D™ Aluminum Railing and Cable System

Materials needed for Installation:



3/8" Lags or Carriage Bolts



Bolt Caps & Cup Washers



Fascia Bracket Screws



Fascia Bracket



Bottom Cap



46" Intermediate Fascia Post

Overview

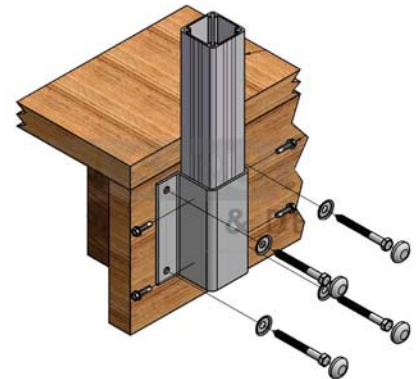

It is the responsibility of the installer to meet all code and safety requirements, and to obtain all required building permits. The deck and railing installer should determine and implement appropriate techniques for each installation situation. AS&D™ or its distributors shall not be held liable for improper or unsafe installations.

Determine appropriate layout and post spacing - **Maximum post spacing of 50" on center.**

Ensure that proper blocking is in place before mounting post.



Step 1:

End post brackets must be installed prior to intermediate bracket placement. A level string is then used to place intermediate bracket. Ensuring all brackets are on same plane.



Step 2:

Determine location of fascia bracket. Ensure bracket is level, mark holes, remove bracket and drill pilot holes to accept 3/8" diameter lag or carriage bolt.



Step 3:

Install cup washer under head of each fastener and drive fastener loosely into blocking.



Step 4:

Ensure bracket is plumb, adjust as needed. Tighten fasteners and ensure proper engagement into blocking.



Step 5:

End posts must be installed prior to intermediate post placement. A level string can be used to properly align all intermediate posts. Posts must be 35-1/2" above deck board for a 36" rail height



Step 6:

While holding post in place, mark bottom of post at bracket edge. Cut post end using a sharp carbide 80 tooth blade on a miter box.

Fascia Mount: Intermediate Post with Bracket

For 36" AS&D™ Aluminum Railing and Cable System



Step 7:

Place bottom cap in post. Secure in place with 2 ea. countersunk screws or epoxy adhesive.



Step 8:

On each side of bracket mark two holes at center line at the same level as the bracket fasteners. Pilot with a 1/4" drill bit.



Step 9:

With bottom of post flush with bottom of bracket, secure post into bracket by installing 4 ea. self-drilling #14 x 1" screws.



Step 10:

Install nylon bolt cap covers for a finished look.

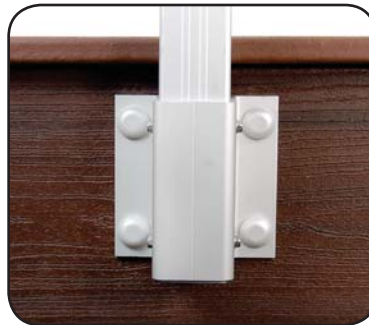

Finished fascia mount bracket with post installed.

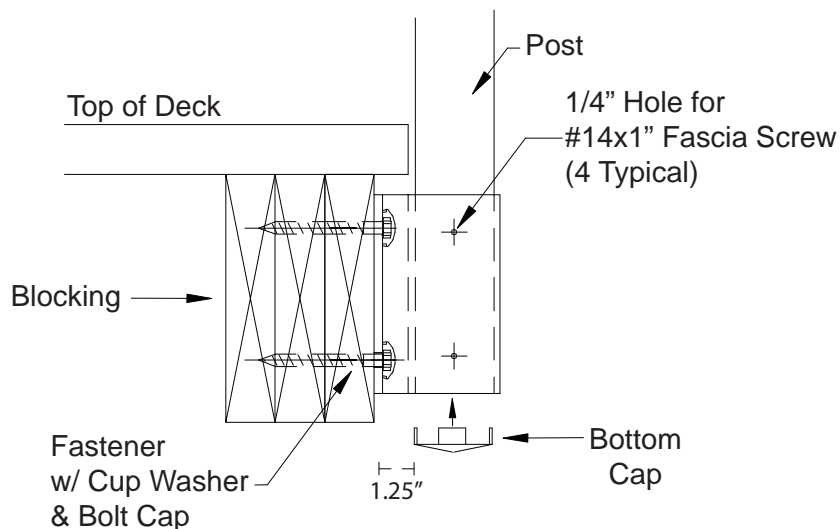



AS&D

Aluminum Railing & Cable Systems

Fascia Mount w/o Brackets





Installation Guide

Fascia Mount: End Post Flush Mount

For 36" AS&D™ Aluminum Railing and Cable System

Materials needed for Installation:

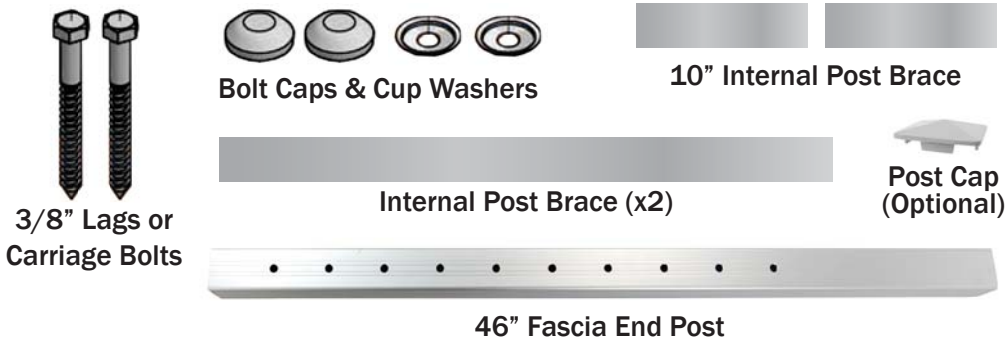

Overview



It is the responsibility of the installer to meet all code and safety requirements and to obtain all required building permits. The deck and railing installer should determine and implement appropriate techniques for each installation situation. AS&D™ or its distributors shall not be held liable for improper or unsafe installations. Determine appropriate layout and post spacing - **Maximum post spacing of 50" on center.** Proper blocking must be in place before mounting posts.



Step 1:

Determine location of end post. (Max. post spacing of 50" on center) Posts must be 35-1/2" above deck board for a 36" rail height.



Step 2:

Mark post at deck height to use as a reference point.



Step 3:

From the mark you created you can measure down to your first hole and mark. Second hole must be 4-1/2" down from the first hole.



Step 4:

Drill holes. If using a drill press you can do both holes at once. Otherwise you should mark and drill both sides separately.



Step 5:

With post laying horizontally, slide 2 ea. 32" Internal Post Braces (IPB) into existing channels perpendicular to pre-drilled fastener holes. IPB's provide necessary rigidity for posts.

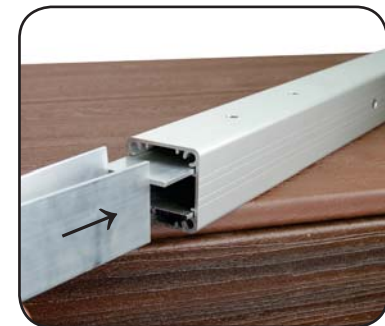

Step 5:

Then, slide 2 ea. 10" Internal Post Braces (IPB) into other channels parallel to pre-drilled fastener holes. IPB's provide support for posts.

Fascia Mount: End Post Flush Mount

For 36" AS&D™ Aluminum Railing and Cable System

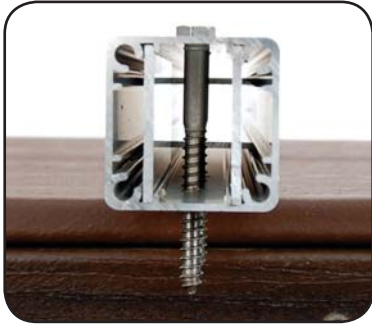

Step 5:
This cross section from the view looking up from the bottom of the post shows how the IPB's crisscross inside the post.



Step 6:
Place bottom cap in post. Secure in place with 2 ea. countersunk screws or epoxy adhesive.



Step 7:
Confirm location of fascia post. (Max. post spacing of 50" on center) Mark holes, remove post and drill pilot holes to accept 3/8" lag or carriage bolt.



Step 8:
Install cup washer under head of each fastener and drive fastener loosely into blocking.



Step 9:
Plumb post, adjust as needed. Tighten fasteners and ensure proper engagement into blocking.



Step 10:
Install nylon bolt cap covers for a finished look.



Step 10:
Finished fascia mount post installed.

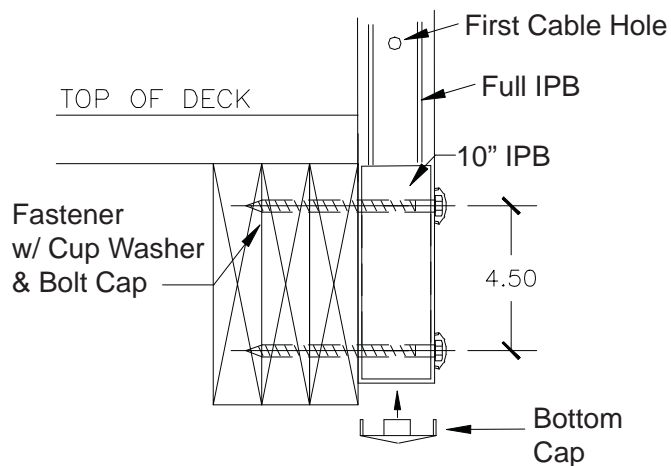



Installation Guide

Fascia Mount: **Intermediate Post** Flush Mount

For 36" AS&D™ Aluminum Railing and Cable System

Materials needed for Installation:



Overview



It is the responsibility of the installer to meet all code and safety requirements and to obtain all required building permits. The deck and railing installer should determine and implement appropriate techniques for each installation situation. AS&D™ or its distributors shall not be held liable for improper or unsafe installations. Determine appropriate layout and post spacing - **Maximum post spacing of 50" on center.** Proper blocking must be in place before mounting posts.



Step 1:

End posts must be installed prior to intermediate post placement. A level string can be used to properly align all intermediate posts. Posts must be 35-1/2" above deck board for a 36" rail height.



Step 2:

Mark post at deck height to use as a reference point.



Step 3:

From the mark you created you can measure down to your first hole and mark. Second hole must be 4-1/2" down from the first hole.



Step 4:

Drill holes. If using a drill press you can do both holes at once. Otherwise you should mark and drill both sides separately.

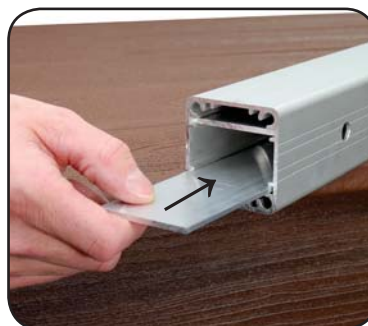

Step 5:

With post laying horizontally, slide 2 ea. 10" Internal Post Braces (IPB) into existing channels parallel to pre-drilled fastener holes. IPB's provide necessary rigidity for posts.



Step 6:

Place bottom cap in post. Secure in place with 2 ea. countersunk screws or epoxy adhesive.



Fascia Mount: **Intermediate Post** Flush Mount

For 36" AS&D™ Aluminum Railing and Cable System



Step 7:

Determine location of fascia post.
(Max. post spacing of 50" on center)
Mark holes, remove post and drill pilot
holes to accept 3/8" lag or carriage bolt.



Step 6:

Install cup washer under head
of each fastener and drive
fastener loosely into blocking.



Step 8:

Plumb post, adjust as needed.
Tighten fasteners and ensure
proper engagement into blocking.



Step 9:

Install nylon bolt cap covers
for a finished look.



Step 10:

Finished fascia mount
post installed.

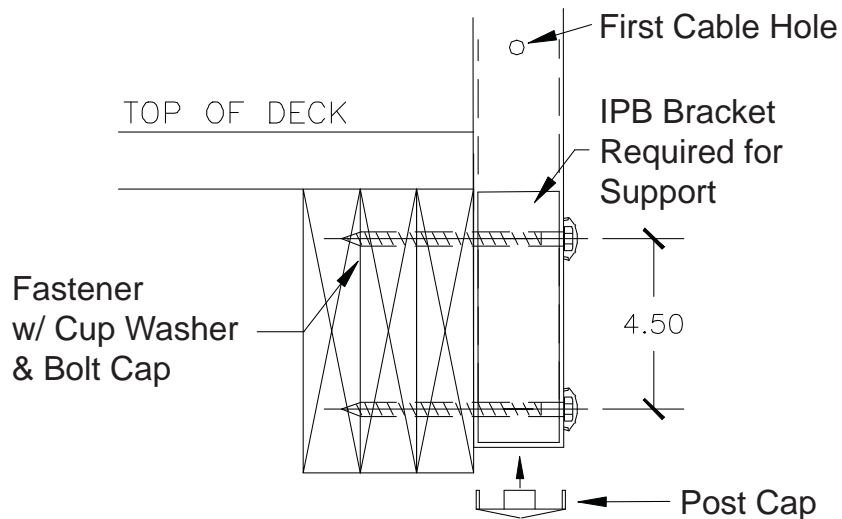

Please contact ADI™ with any questions:

Ph: 1-800-335-5909

Web: www.absolutedist.com

Fax: 800-203-4495

Email: sales@absolutedist.com



AS&D

Aluminum Railing & Cable Systems

Converting Fascia to Surface





Installation Guide

Fascia Mount Post to Surface Mount Post Conversion

Quick Guide for End Post Installation

Materials needed for Installation:



46" End Fascia Post



Base Plate Kit



3/8" Lags or Carriage Bolts



Bolt Caps & Cup Washers



Step 1:

Temporarily attach base plate to undrilled side of fascia end post using 2 screws (Use beeswax for easier install)



Step 2:

Determine location of bottom end post and mark base plate holes.



Step 3:

Temporarily fasten post.

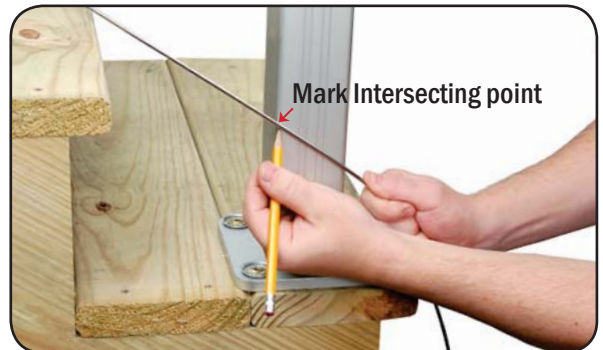
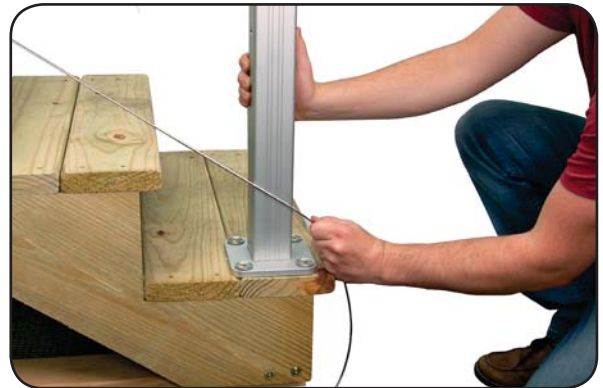
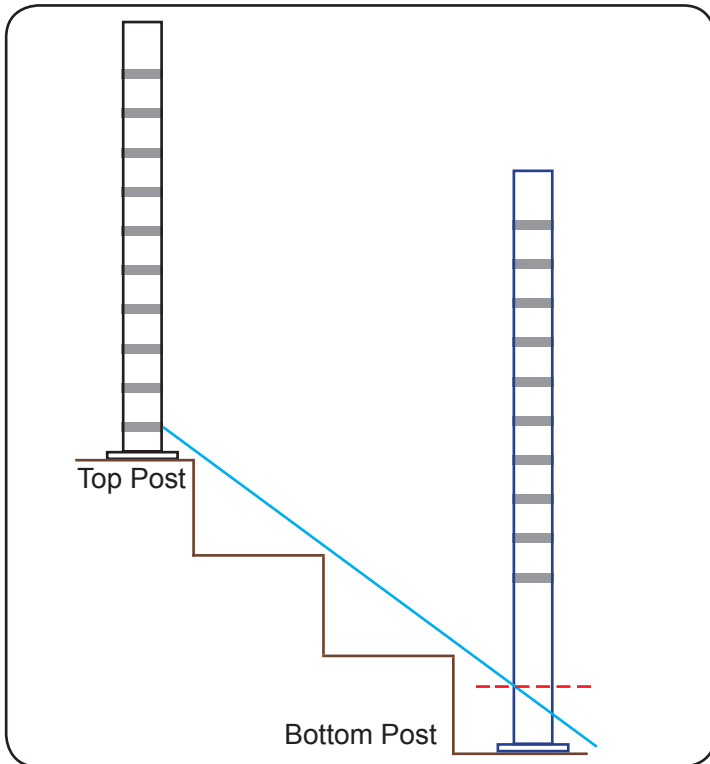

Step 4:

Insert cable into first hole of top end post (previously mounted) and pull tightly along side the bottom end post. Ensure that cable is evenly spaced above the nose of the treads, then mark the bottom end post where the cable intersects the post.

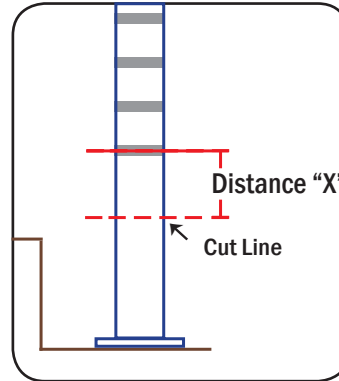
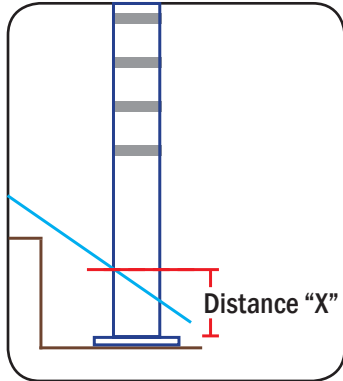

Step 5:

Measure distance (Distance "X") from the mark made in Step 4 to the top of the base plate.

Step 6:

Use Distance "X" from Step 5 and measure down from the center of the first hole (closest to the tread)



Step 7:

Remove post from tread and remove base plate from post before cutting. Then, cut post at the marked cut line from Step 6.



Step 8:

Re-attach base plate to bottom of cut post with all 4 screws. (Use beeswax for easier install)

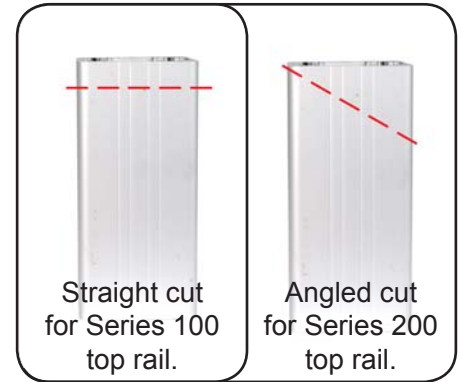

Step 9:

Before final post attachment, the top of post will have to be cut accordingly, so cable is 3-1/2" or less from top rail.



Step 10:

Attach post to surface.



Step 11:

Finished post installation.

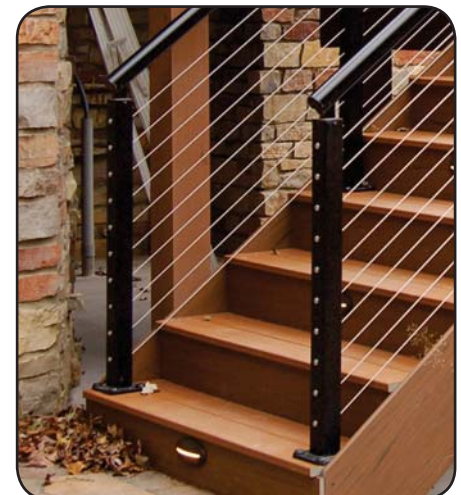



Installation Guide

Fascia Mount Post to Surface Mount Post Conversion

Quick Guide for **Stair Intermediate Post** Installation

Materials needed for Installation:



46" Stair Intermediate Fascia Post



Base Plate Kit



3/8" Lags or Carriage Bolts



Bolt Caps & Cup Washers



Step 1:

Temporarily attach base plate to undrilled side of fascia end post using 2 screws (Use beeswax for easier install)

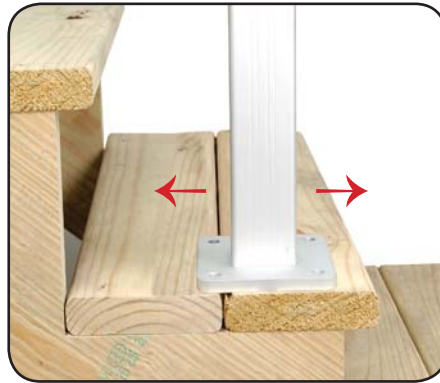

Step 2:

Determine location of intermediate stair post and mark base plate holes.



Step 3:

Temporarily fasten post to tread.

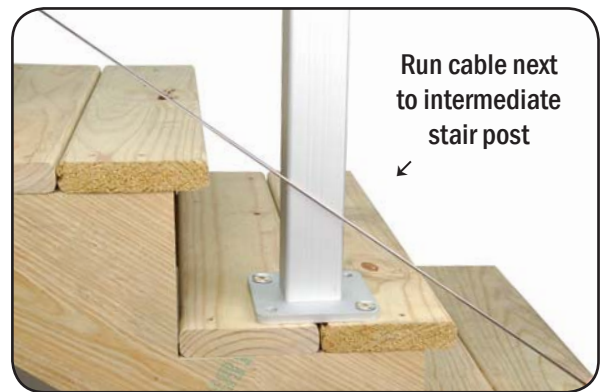
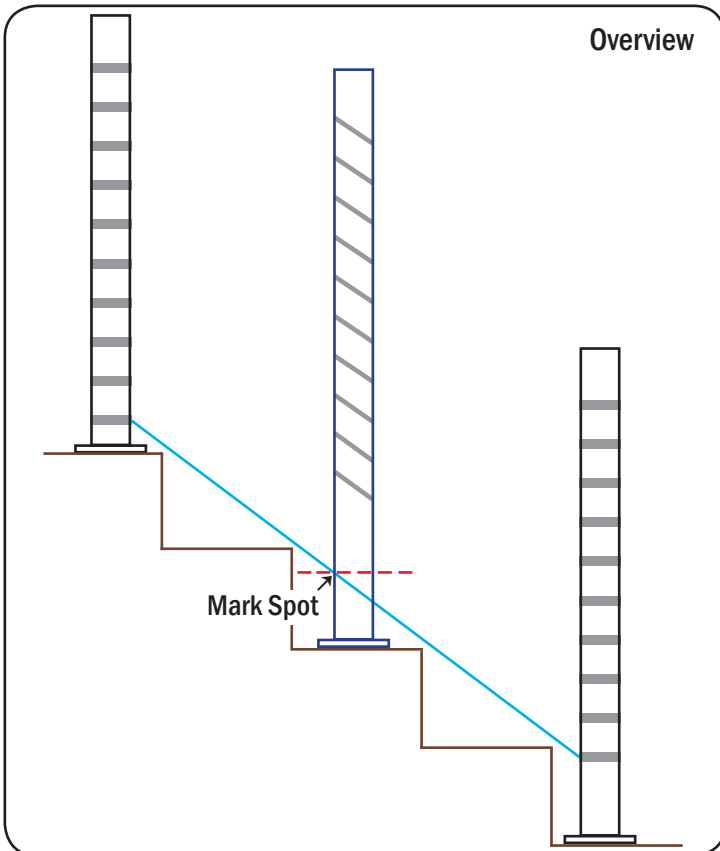

Run cable next to intermediate stair post



Mark Intersecting point

Step 4:

Insert cable into first hole of top and bottom end posts (previously mounted) and temporarily tighten cable with the cable running along side the intermediate stair post. Ensure that cable is evenly spaced above the nose of the treads, then mark the post where the cable intersects the post.

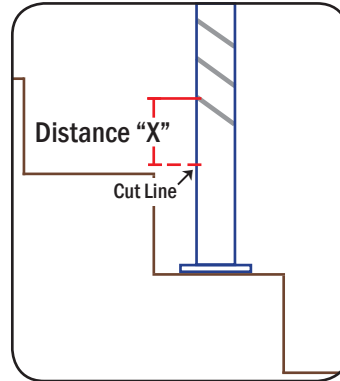
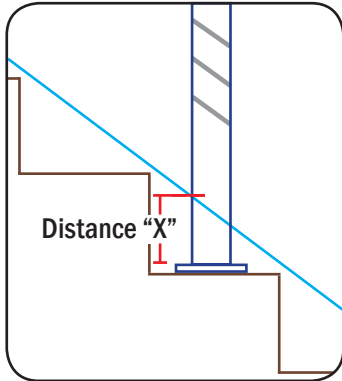

Step 5:

Measure distance (Distance "X") from the mark made in Step 4 to the top of the base plate.

Step 6:

Use Distance "X" from Step 5 and measure down from the center of the first hole (closest to the tread)



Step 7:

Remove post from tread and remove base plate from post before cutting. Then, cut post at the marked cut line from Step 6.



Step 8:

Re-attach base plate to bottom of cut post with all 4 screws. (Use beeswax for easier install)

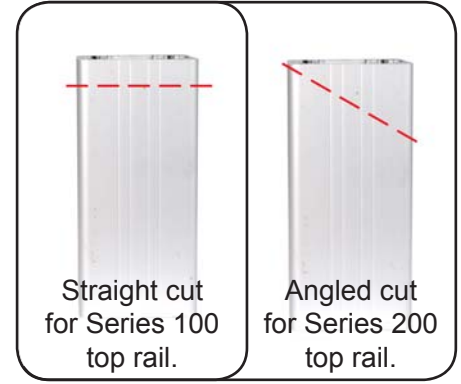

Straight cut for Series 100 top rail.

Angled cut for Series 200 top rail.

Step 9:

Before final post attachment, the top of post will have to be cut accordingly, so cable is 3-1/2" or less from top rail.



Step 10:

Attach post to tread.



Step 11:

Finished post installation.





AS&D

Aluminum Railing & Cable Systems

Gate Installation





Installation Guide Gate For AS&D Rail

For 36" AS&D™ Aluminum Railing and Cable System

Materials needed for Installation:



46" End Fascia Posts - Pre-Drilled
(x2)



Hinge Set



Latch



46" - Series 200 Top Rail (Top)



Series 200 Top
Rail End caps



22405 Cable
Kits (x9)



46" - Series 400 Top Rail (Bottom)

AS&D Gate Overview

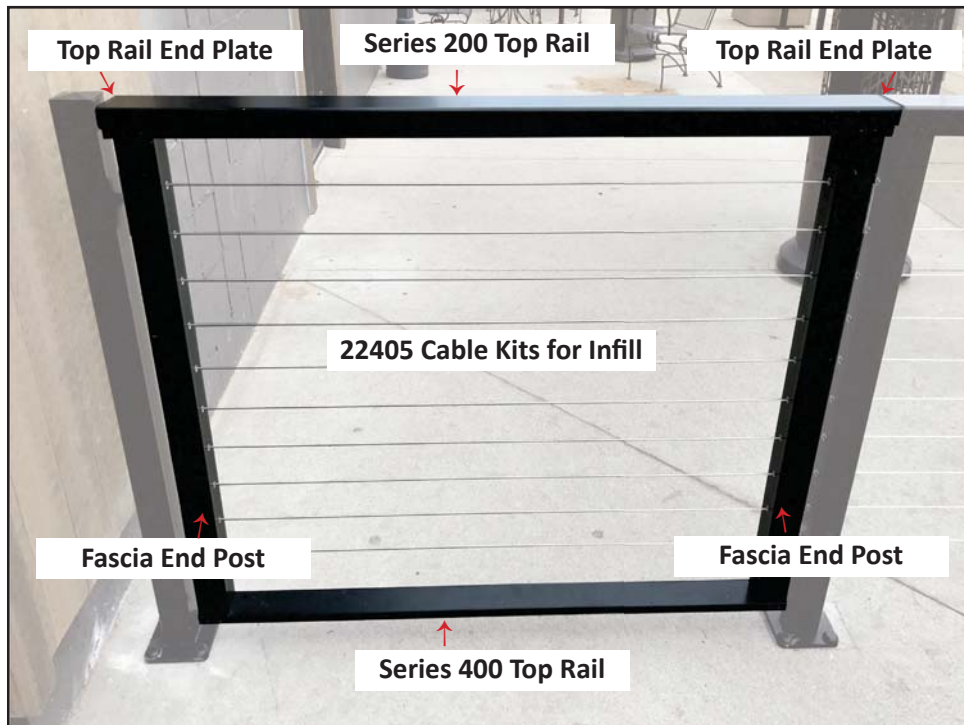

It is the responsibility of the installer to meet all code and safety requirements, and to obtain all required building permits. The deck and railing installer should determine and implement appropriate techniques for each installation situation. AS&D™ or its distributors shall not be held liable for improper or unsafe installations.

Gate for AS&D Rail

For 36" AS&D™ Aluminum Railing and Cable System

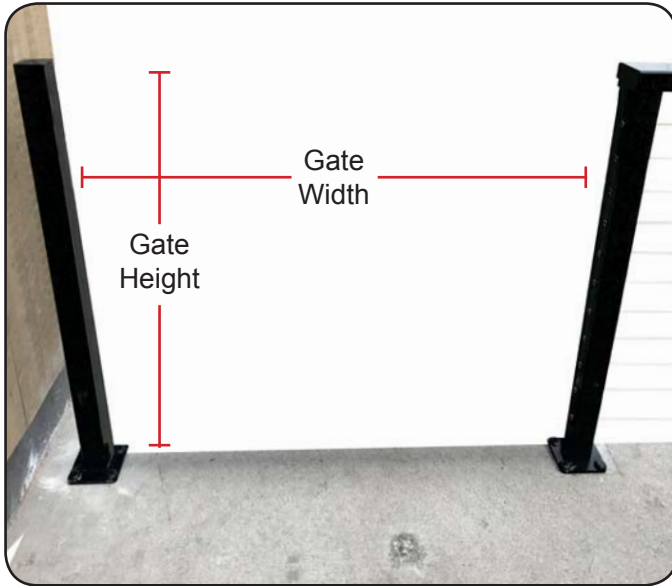

Step 1: Determine Gate Size

Measure the distance between posts to find the gate opening size. (Factor in the distance from bottom rail to surface and leave 1/2" space between the gate and the end posts to allow for hinges and latch)

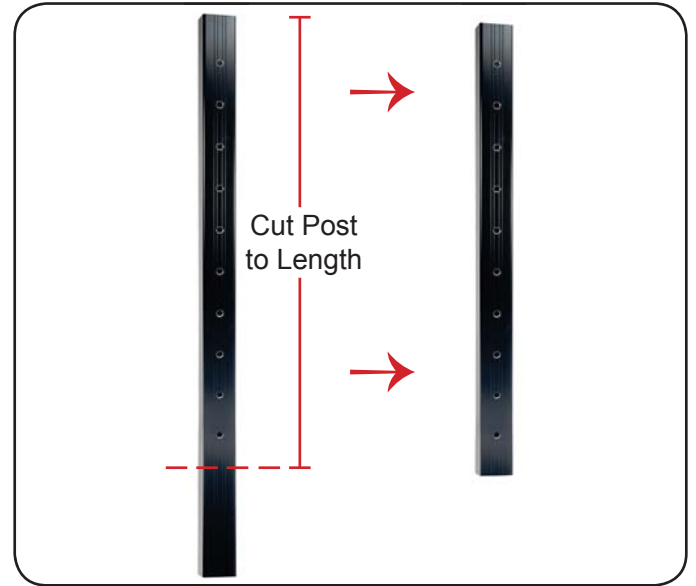

Step 2: Cut Gate End Posts to Size

Gate posts are 46" fascia end posts. Determine the height desired, then cut post to correct length for gate installation. Ensure the pre-drilled holes are centered.

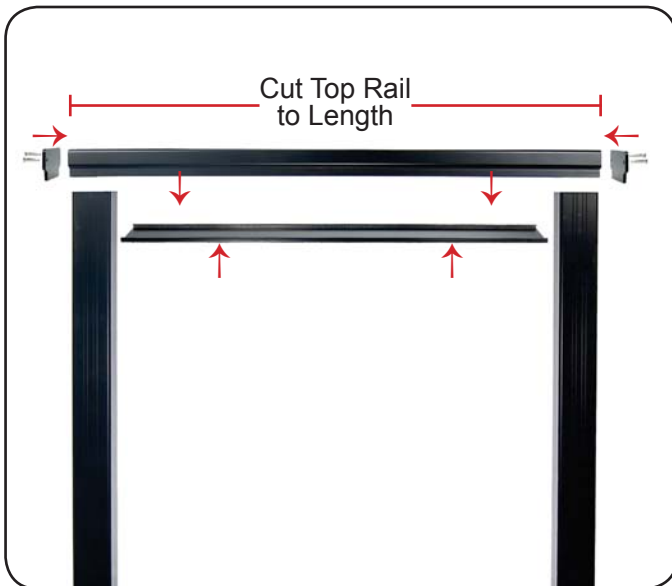

Step 3: Cut Top Rail to Length

After determining the gate width, cut the top rail to proper length. Attach top rail to gate posts using 2 ea. screws on both sides of the post. Then attached top rail end plates. Once attached measure between posts to determine the length of the flat infill piece, cut it to length and snap it into the rail.

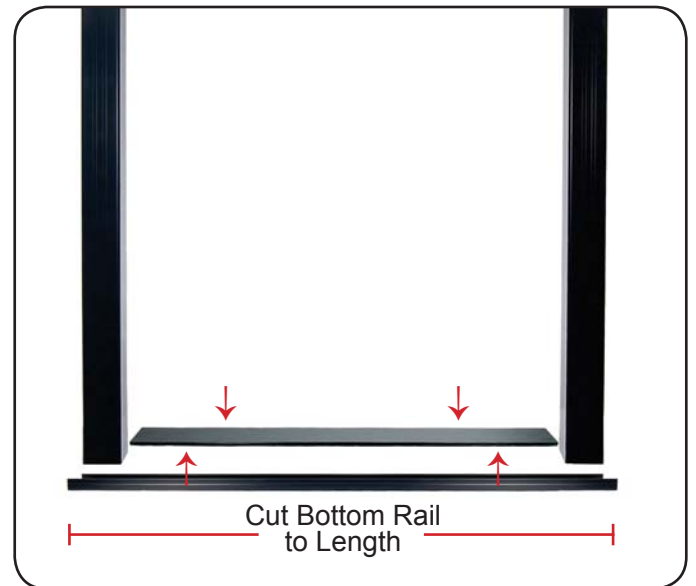

Step 4: Cut Bottom Rail to Length

Series 400 top rail can be used for the bottom rail of a gate. Cut the rail to length and attach it to the bottom of the gate posts using 2 ea. screws on both sides of the post to secure it into place. Once attached measure between posts to determine the length of the flat infill piece, cut it to length and snap it into the rail.

Gate for AS&D Rail

For 36" AS&D™ Aluminum Railing and Cable System



Step 5: Cable Infill

With the gate frame complete, install the cable. Typically 9 runs of cable are used for a 36" gate height. Please follow cable railing installation instructions included with the cable kits.



Step 6: Hinge and Latch

With gate completed, attach the hinges and latch as desired. Use hinges with 1" legs to avoid contact with cable fittings in post. *(Keep hinges close to top and bottom of post to maximize strength)*

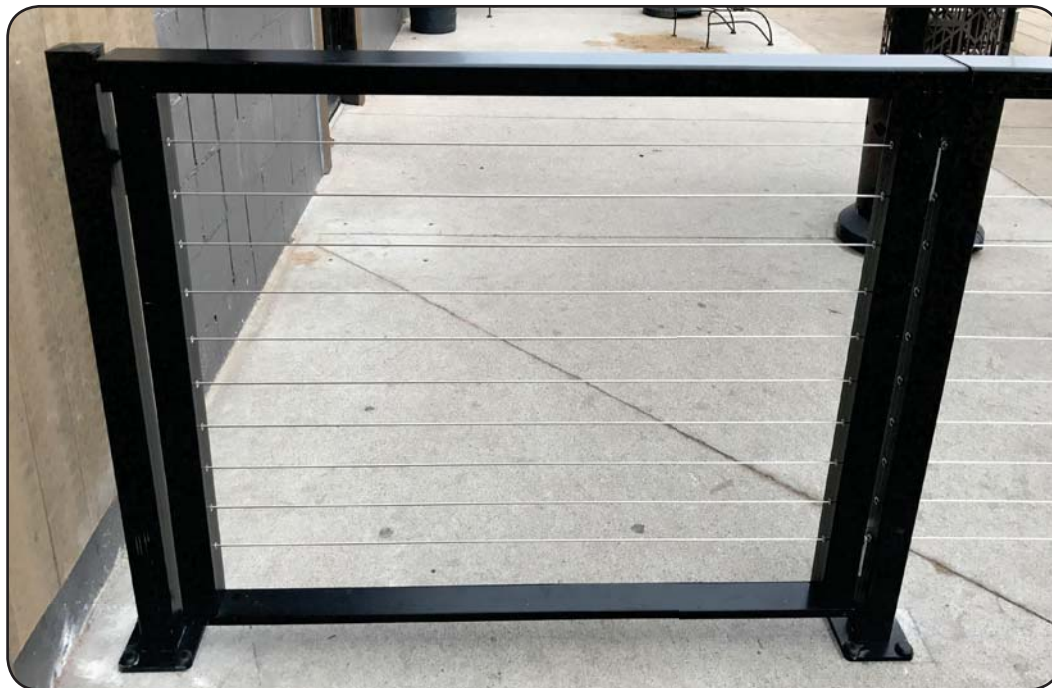

Completed Gate Assembly
(Latch & Hinge on Opposite Side)

AS&D

Aluminum Railing & Cable Systems

Cable Installation Guide



Kit 224 Series Installation Instructions for 2 3/8" Metal Posts



1. Install the tensioning end first with the 2 3/8" long Receiver.
2. Slip the Delrin washer over the body of the Receiver and insert the Receiver into the post.
3. Start the threaded stud attached to the cable into the Receiver and turn 3 complete turns. This will thread about 1/2 of the stud into the Receiver.

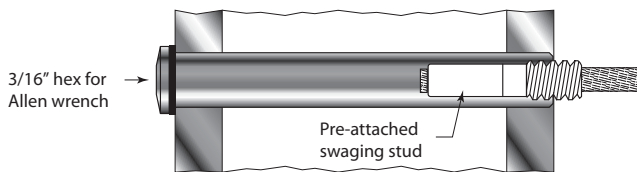

4. Run the bare end of the cable through all your intermediate posts and through the end post where you will be installing the Pull-Lock fitting.

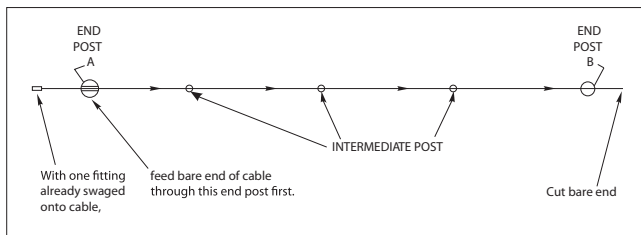

5. Slip the Delrin washer over the body of the Pull-Lock fitting.

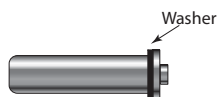

- 6a. Slip the Delrin washer over the body of the Pull-Lock before running cable through the fitting.

- 6b. Push the cable into the hole in front of the Pull-Lock fitting. Twist the cable in the right hand direction as you push it into the fitting. If the cable begins to "unravel" you are rotating it the wrong way. Push the cable until it is through the fitting.

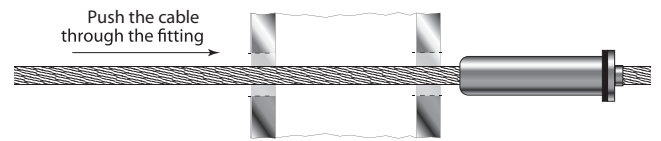

7. Once cable is through the fitting, pull cable while holding the Pull-Lock fitting firmly into the hole in your post. Hold the fitting in place with your hand while pulling the cable through as tightly as you can.

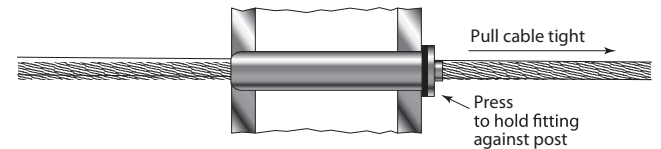

8. Cut the cable flush with the hole in the back of the fitting using a cut-off wheel.

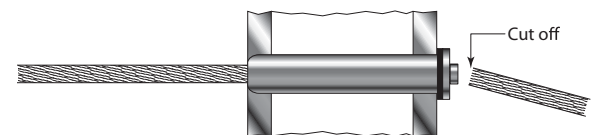

9. Press the cap onto the lip of the Pull-Lock fitting.

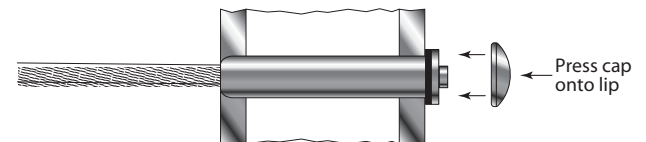

- Go to the other end and tension the cable by holding the cable securely to prevent it from turning while you turn the Receiver with an Allen hex wrench. Be careful to protect the cable from damage while tensioning.

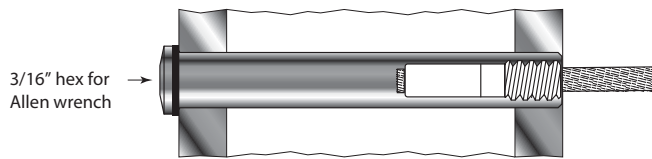
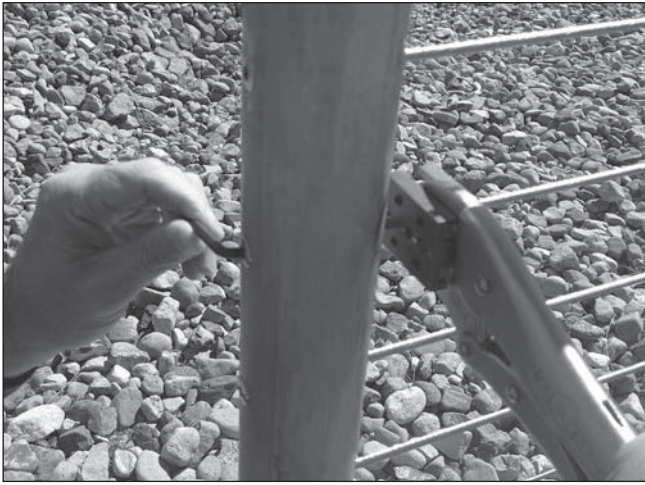

The swaging stud will be pulled into the Receiver by the tensioning.

- Tension in sequence, beginning with the center cable and moving back and forth toward the top and bottom. As you tension each cable, give it a sharp pull downward mid-span to help set the locking wedges in the Pull-Lock fitting. Then re-tension as necessary in the same sequence.

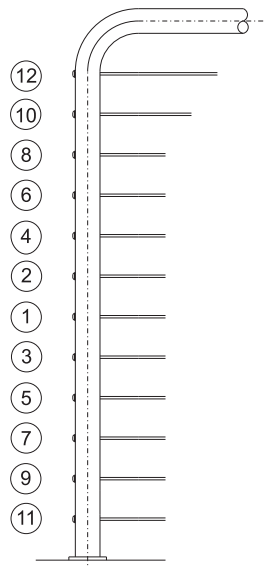

RECOMMENDED TENSIONING SEQUENCE



Marketed and Distributed by:

